

**ILLUSTRATED PARTS LIST
LISTE DES PIECES
STÜCK LISTE**

KUBOTA

MODEL
MODELE **V1505-EB-HAYTER-1**
MODELL

**DIESEL ENGINE
MOTEUR DIESEL
DIESEL MOTOREN**

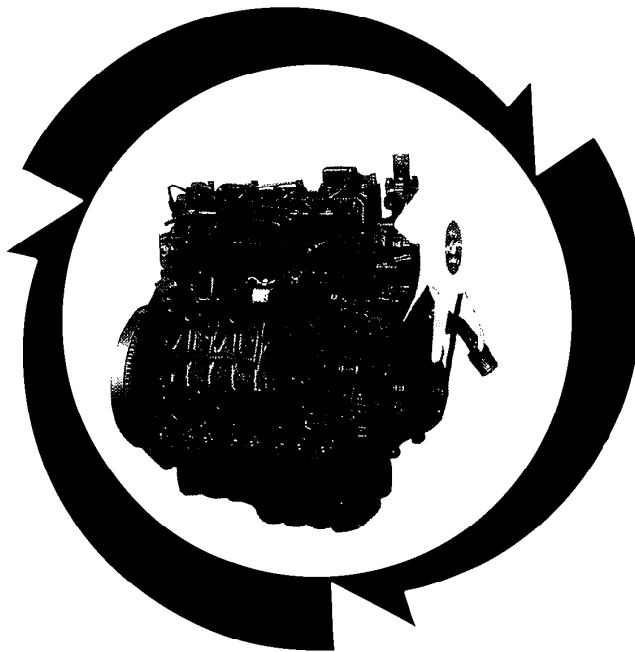

Kubota

97898-63720

APR.

AVRIL

2004

APRIL

NOTICE

This Parts List is for the following purposes.

1. When ordering parts, check with this Parts List to confirm the part number and the name of parts.
2. When making repairs, refer to the illustrations in this Parts List.
3. This Parts List is subject to change without notice.

NOTE

Utilisation de ce livre

1. A la commande d'une pièce, chercher la référence et le nom de la pièce.
2. Pour les réparations, employez les illustrations.
3. La liste des pièces peut-être modifié sans préavis.

ACHTUNG

Die vorliegende Stückliste ist zur Verwendung der folgenden Fälle aufzubewahren:

1. Bei Bestellung der Teile anhand dieser Liste die Kennzahl und die Bezeichnung der Teile feststellen.
2. Bei Reparatur auf die Figur in der Stückliste Bezug nehmen.
3. Änderungen dieser Bestandteilliste vorbehalten.

MODEL MODELE MODELL	CODE No. No. DE CODE CODE-Nr.
V1505-EB-HAYTER-1	1G665-49000

INSTRUCTIONS INSTRUCTION ERKLÄRUNG

①
0102 PISTON AND CRANKSHAFT
PISTON ET VILEBREQUIN
KOLBEN UND KURBELWELLE

②
[B]

⑩ → S.No. ; A: <=15000, B: 14000 to 15000

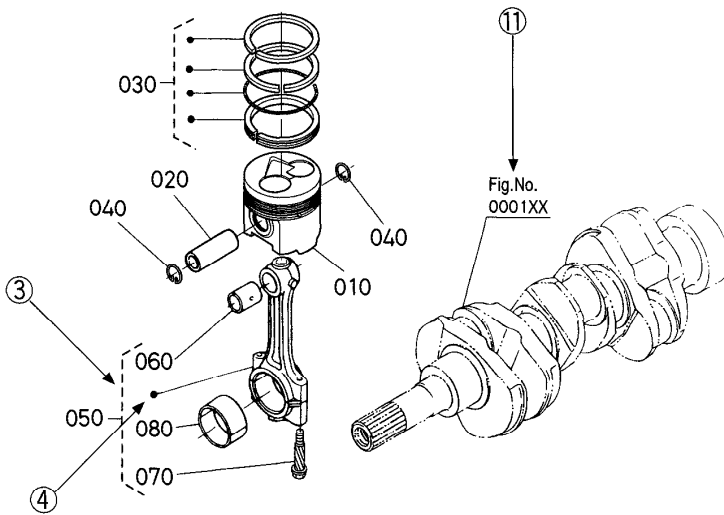

REF. No. POS.No. BILD-Nr.	PART No. REFERENCE BESTELL-Nr.	PART NAME	DESIGNATION	BEZEICHNUNG	QTY/S.No. QTE/No.S. STUECK/S.Nr.		I.C.	REMARKS REMARQUES BEMERKUNGEN
					A	B		
010	15800-0000-0	PISTON	PISTON	KOLBEN	<=15000	<=15000		[Example-1]
010	15800-0000-2	PISTON	PISTON	KOLBEN	>=15001	>=15001		[Exemple-1]
020	15800-1000-0	PIN,PISTON	AXE DE PISTON	KOLBENBOLZEN	<=15000	<=15000		[Beispiel-1]
020	15800-1000-2	PIN,PISTON	AXE DE PISTON	KOLBENBOLZEN	>=15001	>=15001		[Example-2]
030	15800-2000-0	ASSY PISTON RING	ENS.JEU DE SEGMENTS	KOLBENRINGE	<=15000	<=15000		[Exemple-2]
030	15830-2000-0	ASSY PISTON RING	ENS.JEU DE SEGMENTS	KOLBENRINGE	>=15001	>=15001		[Beispiel-2]
								[Example-3]
								[Exemple-3]
								[Beispiel-3]

A:XXXX, B:XXXX

- ① Fig. No. Represents No. corresponding to each group name.
- ② Specifications The types and destinations of sister models are indicated. These indications are given to tell their relevant pages in this book.
(for sister models)
- ③ Components The components of an assembly are identified by a bracket of dotted lines.
- ④ Point Indicates that the parts is not sold independently.
The assembly (Ref.No.050) containing the part needs to be ordered.
- ⑤ REF. No. Reference numbers are assigned to parts in the illustration. The code number of a part in the illustration can be identified by referring to the same reference number in the parts list.
- ⑥ Model name The name of the basic model is indicated in this column. Other applicable models are indicated on the "REMARKS" column ⑨.
- ⑦ S. No. Indicates a group of serial numbers to which a design change is applied.
(serial No.)

Engine Serial No. .. Old Serial No.

654321 ... 6 digits all in numerals.

New Serial No.

Y A 4321

Lower 4 digits in numerals.
5th digit ... Alphabetical letter (Month of manufacture).

Alphabetical letter	A,B	C,D	E,F	G,H	J,K	L,M	N,P	Q,R	S,T	U,V	W,X	Y,Z
Month	1	2	3	4	5	6	7	8	9	10	11	12

6th digit ... Alphabetical letter or numerals (Year of manufacture).

Alphabetical letter or numerals	W	X	Y	1	2	3	4	5	6	7	8	9	A	B	C
Year	'98	'99	2000	'01	'02	'03	'04	'05	'06	'07	'08	'09	'10	'11	'12

- ⑧ I. C. Indicates the interchangeability of parts due to design change.
(interchangeability)
Example-1 ← indicates that a new part can replace an old part, but not vice versa.
15800-0000-0 is applicable to the first serial number to S. No. 15000.
15800-0000-2 is applicable to the first serial number and above.
Example-2 ≠ indicates that the new and old parts are not interchangeable.
15800-1000-0 is applicable to the first serial number to S. No. 15000.
15800-1000-2 is applicable to S. No. 15001 and above.
Example-3 ↔ indicates that the new and old parts are interchangeable. Both 15800-2000-0 and 15830-2000-0 are applicable to the first serial number and above.
- ⑨ REMARKS 1 In this column, enter other applicable model names, dimensions and other special items. The following symbols and abbreviations are used throughout this book.
29*12.00-15 ... Tire size sq.m m² sq.mm mm²
cu.m m³ cu.mm ... mm³ D ... Diameter L Length
- ⑩ REMARKS 2 The following expressions are used in NOTE for each group.
Machines' serial numbers are indicated as follows.
<=15000 Serial number below 15000.
>=15001 Serial number above 15001.
14000 to 15000 Serial number 14000 to 15000.
For some models, the above expressions may also be used REMARKS 1 ⑨.
- ⑪ Fig. No. Indicates the numbers of figures for the parts that are shown in virtual images.
(virtual images)
A figure number with XX means that there are two or more figures depending on the sister models.

- ① No. de Fig. Représente le No. de chaque nom de groupe.
- ② Spécifications Les types et les destinations des modèles soeurs sont indiqués. Ces indications (pour modèles soeurs) sont données pour donner leurs pages relatives dans ce livre.
- ③ Composantes Les composantes d'un ensemble sont identifiées par des parenthèses en pointillé.
- ④ Point Indique que la pièce n'est pas à vendre toute seule. Elle doit être commandée avec l'ensemble (POS.No. 050) qui la contient.
- ⑤ POS.No. Des numéros de position sont donnés aux pièces représentées dans l'illustration. Le référence d'une pièce de l'illustration peut être identifié en se reportant au même numéro de position indiqué dans la liste des pièces détachées.
- ⑥ Nom de type Le nom du type de base est indiqué dans cette colonne. Les autres modèles sont indiqués dans la colonne des "REMARQUES" ⑨.
- ⑦ No. S. Indique un groupe de numéros de série qui a subit des modifications de modèle. (No. de série)

No. de série No. de série vieux
de moteur 654321 ... Tous 6 chiffres en numerals.

No. de série nouveau

Y A 4321

↑ 4 chiffres inférieures en numerals.

↑ 5^{ème} chiffre ... Lettre alphabétique (Mois de fabrication).

Lettre alphabétique	A,B	C,D	E,F	G,H	J,K	L,M	N,P	Q,R	S,T	U,V	W,X	Y,Z
Mois	1	2	3	4	5	6	7	8	9	10	11	12

↑ 6^{ème} chiffre ... Lettre alphabétique ou numeral (Année de fabrication).

Lettre alphabétique ou numeral	W	X	Y	1	2	3	4	5	6	7	8	9	A	B	C
Année	'98	'99	2000	'01	'02	'03	'04	'05	'06	'07	'08	'09	'10	'11	'12

- ⑧ I. C. Indique la permutabilité des pièces due à un changement dans le modèle. (permutabilité)
 - Exemple-1 ← indique que la nouvelle pièce peut remplacer la vieille, mais pas vice versa. Le 15800-0000-0 s'applique au premier numéro de série jusqu'au No.S. 15000. Le 15800-0000-2 s'applique au premier numéro de série et à ceux ci-dessus.
 - Exemple-2 ≠ indique que la nouvelle et vieille pièces sont permutable. Le 15800-1000-0 s'applique au premier numéro de série jusqu'au No.S. 15000. Le 15800-1000-2 s'applique au No.S. 15001 et à ceuxci-dessus.
 - Exemple-3 ↔ indique que la nouvelle piése et la vieille pièce sont interchangeable. Toules deux numéros 15800-2000-0 et 15830-2000-0 sont applicables a premier numéro de cette depuis.
- ⑨ REMARQUES 1 ... Cette colonne renferme d'autres noms de modèles applicables, les dimensions et autres éléments spéciaux. Les symboles abréviations suivants sont utilisés dans l'ensemble de ce manuel. 29*12.00-15 ... Dimension des pneus sq.m ... m² sq.mm ... mm² cu.m ... m³ cu.mm .. mm³ D ... Diamètre L ... Longueur
- ⑩ REMARQUES 2 ... Les expressions suivantes sont utilisées dans la NOTE de chaque groupe. Les numéros de série des machines sont indiqués de la manière suivante. <=15000 Numéros de série au-dessous de 15000. >=15001 Numéros de série au-dessus de 15001. 14000 to 15000 Numéros de série 14000 à 15000. Pour certaines modèles, les expressions ci-dessus peuvent aussi être utilisées dans la rubrique des REMARQUES 1 ⑨.
- ⑪ No. de Fig. Indique les numéros de figures pour les pièces qui sont illustrées dans les images (images virtuelles) virtuelles. Un numéro de figure avec XX signifie qu'il y a plus de deux figures selon les modèles soeurs.

- ① Abb. Nr. Diese Nummer bezieht sich auf die jeweilige Gruppenbezeichnung.
- ② Spezifikationen Die Typen und Bestimmungsorte der Schwestermodelle sind angegeben. Die Angaben beziehen sich auf die entsprechenden Seiten in diesen Handbuch.
(für Schwestermodelle)
- ③ Einzelteile Die Einzelteile einer Baugruppe sind durch eine Klammer aus gestrichelten Linien gekennzeichnet.
- ④ Punkte Punktierung zeigt an, daß das entsprechende Teil nicht einzeln erhältlich ist. Die gesamte Baugruppe, die dieses Teil beinhaltet muß bestellt werden. (BILD-Nr. 050).
- ⑤ BILD-Nr. Die Teile in den Abbildungen sind mit Bezugsnummern versehen. Die Kennnummer eines der abgebildeten Teile erhalten Sie, wenn Sie unter der Bezugsnummer in der Ersatzteilliste nachsehen.
- ⑥ Typenbezeichnung ... In dieser Spalte wird die Bezeichnung des Grundtype aufgeführt. Weiter Modelle, die verwendet werden können werden unter "BEMERKUNGEN" in Spalte ⑨ angegeben.
- ⑦ S. Nr. Bezeichnet eine Gruppe Seriennummern, bei der Änderungen in der Ausführung vorgenommen wurden.
(Serien Nr.)

Motor-Serien-Nr. ... Alte Serien-Nr.

654321 ... Alle 6 Stellen mit Ziffern.

Neue Serien-Nr.

Y A 4321

Untere 4 Stellen mit Ziffern.

5. Stelle ... Buchstabe (Herstellungsmonat).

Buchstabe	A,B	C,D	E,F	G,H	J,K	L,M	N,P	Q,R	S,T	U,V	W,X	Y,Z
Monat	1	2	3	4	5	6	7	8	9	10	11	12

6. Stelle ... Buchstabe oder Ziffer (Herstellungsjahr).

Buchstabe oder Ziffer	W	X	Y	1	2	3	4	5	6	7	8	9	A	B	C
Jahr	'98	'99	2000	'01	'02	'03	'04	'05	'06	'07	'08	'09	'10	'11	'12

- ⑧ I. C. Bezeichnet die Austauschmöglichkeit der Teile untereinander bei einer Änderung in der Ausführung.
(Austauschmöglichkeit)
- Beispiel- 1 ← besagt, daß das alte Teil durch ein neues ersetzt werden kann, nicht jedoch umgekehrt. 15800-0000-0 bezieht sich auf die erste Serien Nr. bis S.Nr. 15000.
15800-0000-2 bezieht sich auf die erste Serien Nr. und darüber.
- Beispiel- 2 ≠ besagt, daß alte und neue Teile nicht austauschbar sind.
15800-1000-0 bezieht sich auf die erste Serien Nr. bis S.Nr. 15000.
15800-1000-2 bezieht sich auf S.Nr. 15001 und darüber.
- Beispiel- 3 ↔ besagt, daß alte und neue Teile austauschbar sind. Beiderseitig 15800-2000-0 und 15830-2000-0 bezieht sich auf die erste Serien Nr. und darüber.
- ⑨ BEMERKUNGEN 1 .. In dieser Spalte finden Sie weitere verwendbare Modellbezeichnungen, Abmessungen und andere besondere Angaben.
Die folgenden Symbole und Abkürzungen werden im Gesamtext des Buches benutzt : 29 * 12.00-15 Reifengrößen sq.m m² sq.mm mm²
cu.m m³ cu.mm mm³ D Durchmesser L Länge
- ⑩ BEMERKUNGEN 2 .. Die folgenden Ausdrücke werden in "NOTE" für jede Gruppe verwendet.
Seriennummern von Maschinen werden wie folgt angezeigt :
<=15000 ... Seriennummern unter 15000.
>=15001 Seriennummern über 15001.
14000 to 15000 Seriennummern 14000 bis 15000.
Bei einigen Modellen können die oben genannten Ausdrücke auch in "ANMERKUNGEN 1 ⑨" verwendet werden.
- ⑪ Abb. Nr. Bezeichnet die Nummern der Abbildungen für die Teile, die in virtuellen Bildern illustriert sind. Ein Abbildungsnummer mit XX bedeutet, daß sich zwei oder mehrere Abbildungen gemäß den Schwestermodellen befinden.
(virtuellen Bildern illustriert sind)

CONTENTS

0001	CRANKCASE	1
0002	OIL PAN	2
0003	CYLINDER HEAD	3
0004	GEAR CASE	4
0005	HEAD COVER	5
0006	OIL FILTER	6
0007	DIPSTICK AND GUIDE	7
0100	MAIN BEARING CASE	8
0101	CAMSHAFT AND IDLE GEAR SHAFT	9
0102	PISTON AND CRANKSHAFT	10
0103	FLYWHEEL	12
0105	FUEL CAMSHAFT AND GOVERNOR SHAFT	13
0180	IDLE APPARATUS	14
0201	STOP SOLENOID	15
0202	INJECTION PUMP	16
0205	SPEED CONTROL PLATE	17
0206	NOZZLE HOLDER AND GLOW PLUG	18
0207	NOZZLE HOLDER (COMPONENT PARTS)	19
0212	FORK LEVER (GOVERNOR)	20
0300	FUEL FILTER	21
0301	FUEL PUMP (MECHANICAL)	22
0402	ALTERNATOR AND PULLEY	23
0403	ALTERNATOR (COMPONENT PARTS)	24
0404	STARTER	25
0405	STARTER (COMPONENT PARTS)	26
0406	OIL SWITCH/THERMOMETER AND PLUG	27
0500	WATER FLANGE AND THERMOSTAT	28
0501	WATER PUMP	29
0503	WATER PIPE	30
0504	FAN	31
0600	VALVE AND ROCKER ARM	32
0601	INLET MANIFOLD	33
0602	EXHAUST MANIFOLD	34
0604	INLET PIPE	35
0605	MUFFLER	36
0700	HYDRAULIC PUMP	37
0800	GLOW LAMP AND TIMER	38
0809	LABEL AND OPERATOR'S MANUAL	39

SOMMAIRE

0001	BLOC MOTEUR	1
0002	CARTER D' HUILE	2
0003	CULASSE	3
0004	CARTER DE DISTRIBUTION	4
0005	COUVRE-CULASSE	5
0006	FILTRE D' HUILE	6
0007	JAUGE D' HUILE ET GUIDE	7
0100	PALERS DE VILEBREQUIN	8
0101	ARBRE A CAMES ET ARBRE DE PIGNON DE RALE NTI	9
0102	PISTON ET VILEBREQUIN	10
0103	VOLANT MOTEUR	12
0105	ARBRE A CAMES DE CARBURANT ET ARBRE REGU LATEUR	13
0180	DISPOSITIF DE RALENTISSEUR	14
0201	SOLENOIDE D' ARRET	15
0202	POMPE D' INJECTION	16
0205	PLAQUE DE VITESSE-CONTROLE	17
0206	PORTE-INJECTEUR ET BOUGIE DE PRECHAUFFAG E	18
0207	PORTE-INJECTEUR (PARTIES COMPOSANTES)	19
0212	LEVIER A FOURCHE (REGULATEUR DE VITESSES)	20
0300	FILTRE A CARBURANT	21
0301	POMPE D' ALIMENTATION (MECHANIQUE)	22
0402	ALTERNATEUR	23
0403	ALTERNATEUR (PARTIES COMPOSANTES)	24
0404	DEMARREUR	25
0405	DEMARREUR (PARTIES COMPOSANTES)	26
0406	CONTACT A HUILE/THERMOMETRE ET OBTURATEU R	27
0500	BRIDE A EAU ET THERMOSTAT	28
0501	POMPE A EAU	29
0503	TUYAU D' EAU	30
0504	VENTILATEUR	31
0600	SOUPAPES ET CULBUTEURS	32
0601	COLLECTEUR D' ADMISSION	33
0602	COLLECTEUR D' ECHAPPEMENT	34
0604	TUYAU D' ADMISSION	35
0605	SILENCIEUX	36
0700	POMPE HYDRAULIQUE	37
0800	INDICATEUR DE PRECHAUFFAGE ET TEMPORISAT EUR	38
0809	ETIQUETTE ET MANUEL DE L' UTILISATEUR	39

INHALTSVERZEICHNIS

0001	KURBELGEHAEUSE	1
0002	OELWANNE	2
0003	ZYLINDERKOPF	3
0004	GETRIEBEGEHAEUSE	4
0005	ZYLINDERKOPF-DECKEL	5
0006	OELFILTER	6
0007	OELMESSSTAB UND FUEHRUNG	7
0100	HAUPTLAGERGEHAEUSE	8
0101	NOCKENWELLE UND FREILAUFGETRIEBEWELLE	9
0102	KOLBEN UND KURBELWELLE	10
0103	SCHWUNGRAD	12
0105	KRAFTSTOFF-NOCKENWELLE UND ACHSE	13
0180	FREILAUFAPPARAT	14
0201	ABSTELLSOLENOID	15
0202	EINSPRITZENPUMPE	16
0205	GESCHWINDIGKEITS-REGLERPLATTE	17
0206	DUESENHALTER UND GLUEHKERZE	18
0207	DUESENHALTER (EINZEL-TEIL)	19
0212	HEBEL-GABEL (REGLER)	20
0300	KRAFTSTOFFFILTER	21
0301	KRAFTSTOFFPUMPE (MECHANISCH)	22
0402	WECHSELSTROMMASCHINE	23
0403	WECHSELSTROMMASCHINE (EINZEL-TEIL)	24
0404	ANLASSER	25
0405	ANLASSER (EINZEL-TEIL)	26
0406	OELSCHALTER/THERMOMETER UND VERSCHLUSSS TOPFEN	27
0500	WASSERFLANSCH UND THERMOSTAT	28
0501	WASSERPUMPE	29
0503	WASSERROHR	30
0504	VENTILATOR	31
0600	VENTIL UND KIPPENARM	32
0601	ANSAUGENLEITUNG	33
0602	AUSPUFFRUEMMER	34
0604	ANSAUGENROHR	35
0605	AUSPUFFTOPF	36
0700	HYDRAULIKPUMPE	37
0800	GLUEHLAMPE UND ZEITMESSER	38
0809	ETIKETTE UND HANDHABUNG-GEBRAUCHSANWEISU NG	39

0001

**CRANKCASE
BLOC MOTEUR
KURBELGEHAEUSE**

NOTE: ORDER BY REF. No. 010 NEW PART and Fig. No. 0007 REF. No. 050

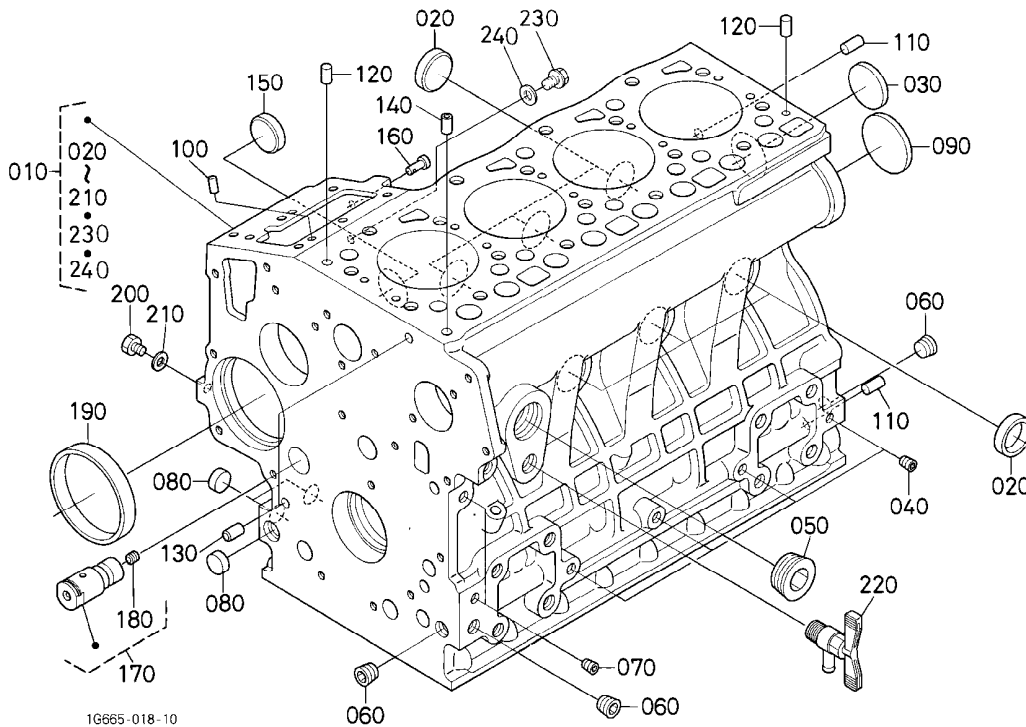

A: V1505-EB-HAYTER-1

REF. No. POS. No. BILD-Nr.	PART No. REFERENCE BESELL-Nr.	PART NAME	DESIGNATION	BEZEICHNUNG	QTY/S. No. QTE/No. S. STUECK/S. Nr.		I. C.	REMARKS REMARQUES BEMERKUNGEN
					A	B		
010	17558-0101-8	COMP. CRANKCASE	BLOC MOTEUR COMPLET	KOMP. KURBELGEHAEUSE	1	-		NOT SALE. SEE NOTE
010	17558-0101-9	COMP. CRANKCASE	BLOC MOTEUR COMPLET	KOMP. KURBELGEHAEUSE	1	-	≠	
020	15451-9627-0	CAP. SEALING	PASTILLE	STOEPSSEL, ABDICHTUNG	6	-		
030	15221-0349-0	CAP. SEALING	PASTILLE	STOEPSSEL, ABDICHTUNG	1	-		
040	15261-9601-0	PLUG	BOUCHON	STOPFEN	4	-		
050	16683-9602-0	PLUG	BOUCHON	STOPFEN	1	-		
060	16241-9601-0	PLUG	BOUCHON	STOPFEN	3	-		
070	15521-9602-0	PLUG	BOUCHON	STOPFEN	2	-		
080	17391-9616-0	PLUG, EXPANSION	BOUCHON EXPANSIBLE	STOEPSSEL, AUSDEHNUNG	3	-		
090	16271-9616-0	PLUG, EXPANSION	BOUCHON EXPANSIBLE	STOEPSSEL, AUSDEHNUNG	1	-		
100	05012-00508	PIN, STRAIGHT	GOUPILLE CYLINDRIQUE	ZYLINDERSTIFT	2	-		
110	05012-00814	PIN, STRAIGHT	GOUPILLE CYLINDRIQUE	ZYLINDERSTIFT	2	-		
120	16221-9452-0	PIN, STRAIGHT	GOUPILLE CYLINDRIQUE	ZYLINDERSTIFT	2	-		
130	15231-3396-0	PIN, PIPE	GICLEUR	ROHRSTIFT	2	-		
140	16241-3365-0	PIN, PIPE	GICLEUR	ROHRSTIFT	1	-		
150	16241-9626-2	PLUG	BOUCHON	STOPFEN	1	-		
160	16221-5628-0	PIN, START SPRING	GOUPILLE DU RESSORT	STARTFEDERSTIFT	1	-		
170	16241-2406-0	COMP SHAFT, IDLE	COMP. ARBRE D'INTERM.	KOMP. FREILAUFWELLE	1	-		
180	15521-9361-0	SCREW, SET	VIS D'ARRET	ANSCHLAGSCHRAUBE	1	-		
190	16271-5535-0	BUSH, GOVERNOR GEAR	BAGUE DE REG. PIGNON	BUCHSE	1	-		
200	15221-3361-0	PLUG	BOUCHON	STOPFEN	1	-		
210	15021-3366-0	GASKET	JOINT	DICHTUNGSPLATTE	1	-		
220	15841-7302-0	ASSY COCK, DRAIN	ENS. ROBINET VIDANGE	GRP. ABLASSHAHN	1	-		
230	01754-50610	BOLT, FLANGE	VIS DE BUTEE	FLANSCHEN-BOLZEN	1	-		
240	15601-9665-0	GASKET	JOINT	DICHTUNGSPLATTE	1	-		

↔ Interchangeable; ≠ not interchangeable; ← new for old; → old for new

0002

OIL PAN CARTER D' HUILE OELWANNE

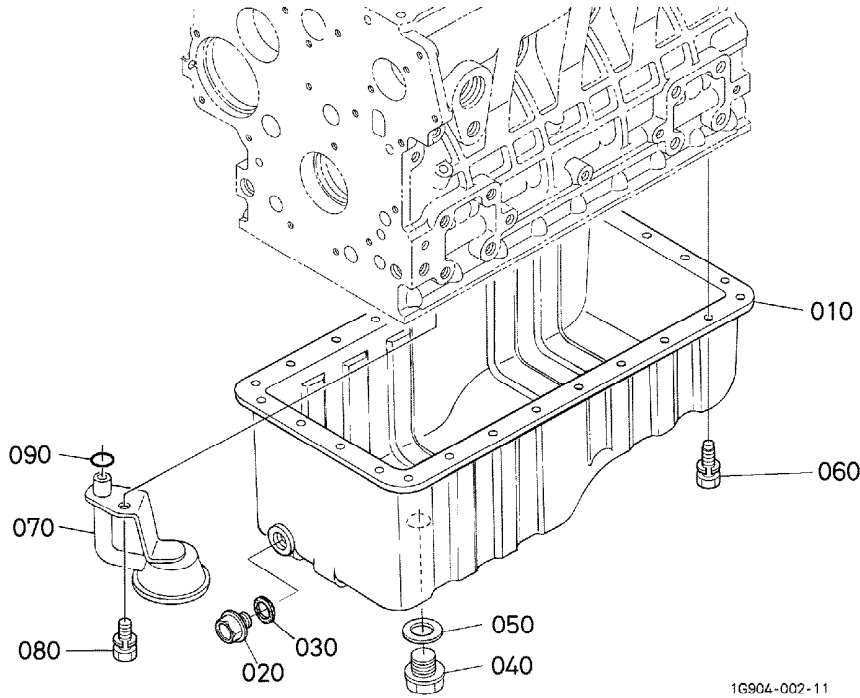

1G904-002-11

A: V1505-EB-HAYTER-1

REF. No. POS. No. BILD-Nr.	PART No. REFERENCE BESELL-Nr.	PART NAME	DESIGNATION	BEZEICHNUNG	QTY/S. No. QTE/No. S. STUECK/S. Nr.		I. C.	REMARKS REMARQUES BEMERKUNGEN
					A	B		
010	16616-0150-0	COMP. OIL PAN	CARTER D' HUILE COMP.	KOMP. OELWANNE	1	-		
020	16326-3375-0	PLUG, DRAIN	BOUCHON DE VIDANGE	ENTLEERUNGSSTOPFEN	1	-		
030	6C090-5896-0	GASKET	JOINT	DICHTUNGSPLATTE	1	-		
040	16286-3375-0	PLUG, DRAIN	BOUCHON DE VIDANGE	ENTLEERUNGSSTOPFEN	1	-		
050	15451-9667-0	GASKET	JOINT	DICHTUNGSPLATTE	1	-		
050	16265-9667-0	GASKET	JOINT	DICHTUNGSPLATTE	<=5H1534	-		
060	16221-9112-0	BOLT	VIS	BOLZEN	>=5J0007 26	-	←	
070	16226-3211-0	FILTER, OIL	FILTRE D' HUILE	OELFILTER	<=5X2438	-		
070	16226-3211-4	FILTER, OIL	FILTRE D' HUILE	OELFILTER	>=5Y0004	-	←	
080	01123-60816	BOLT	VIS	BOLZEN	1	-		
090	04814-00160	O RING	JOINT TORIQUE	O RING	1	-		

↔ Interchangeable; ≠ not interchangeable; ← new for old; → old for new

0003

CYLINDER HEAD
CULASSE
ZYLINDERKOPF

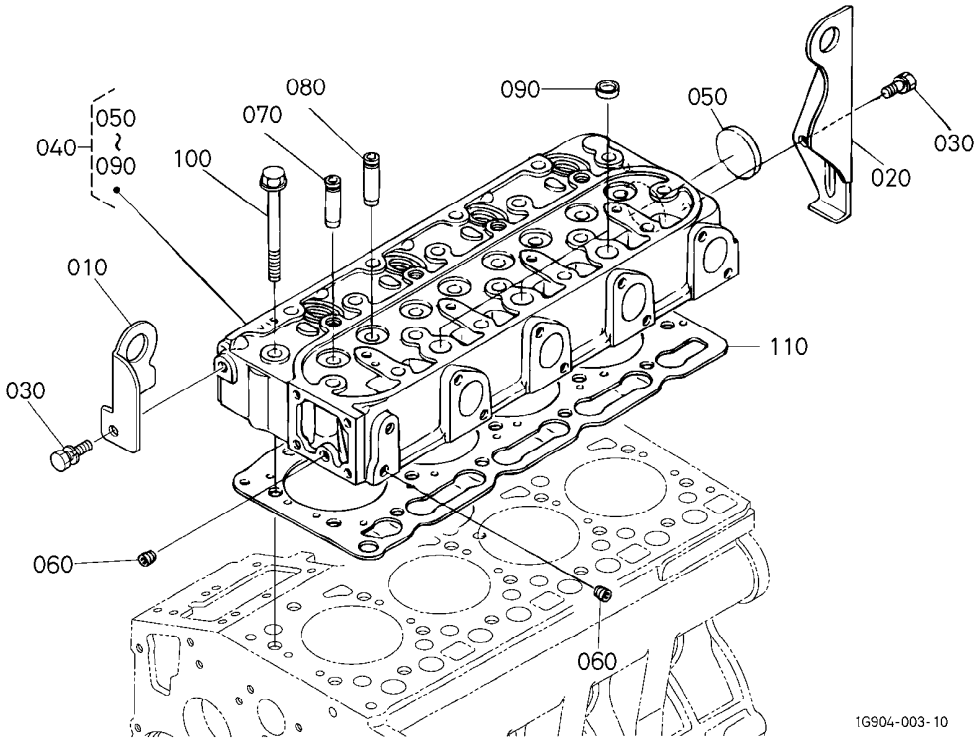

A: V1505-EB-HAYTER-1

REF. No. POS. No. BILD-Nr.	PART No. REFERENCE BESELL-Nr.	PART NAME	DESIGNATION	BEZEICHNUNG	Q'TY/S. No. Q'TE/No. S. STUECK/S. Nr.		I. C.	REMARKS REMARQUES BEMERKUNGEN
					A	B		
010	16241-0175-0	HOOK, ENGINE	ANNEAU DE LEVAGE	MOTOR-ANKERHAKEN	1	-		
020	16241-0177-0	HOOK, ENGINE	ANNEAU DE LEVAGE	MOTOR-ANKERHAKEN	1	-		
030	01123-60814	BOLT	VIS	BOLZEN	2	-		
040	16060-0304-2	COMP. CYLINDER HEAD	CULASSE COMPLET	KOMP. ZYLINDERKOPF	1	-		
050	15321-9626-0	CAP, SEALING	PASTILLE	STOEPSSEL, ABDICHTUNG	1	-		
060	15261-9601-0	PLUG	BOUCHON	STOPFEN	2	-		
070	16261-1354-0	GUIDE, INLET VALVE	GUIDE SOUP. D' ADMISS.	EINLASSVENTILFUHRUNG	4	-		
080	16261-1356-0	GUIDE, EXHAUST VALVE	GUIDE SOUP. D' ECHAP.	AUSLASSVENTILFUHRUNG	4	-		
090	15261-0337-0	CAP, SEALING	PASTILLE	STOEPSSEL, ABDICHTUNG	3	-		
100	16241-0345-0	BOLT, CYLINDER HEAD	VIS DE CYLINDRE	ZYLINDERKOPFSCHRAUBE	18	-		
110	16394-0331-0	GASKET, CYLINDER HEAD	JOINT	DICHTUNG, ZYLINDERKOPF	1	-		

↔ interchangeable; ≠ not interchangeable; ← new for old; → old for new

0004

GEAR CASE
CARTER DE DISTRIBUTION
GETRIEBEGEHAEUSE

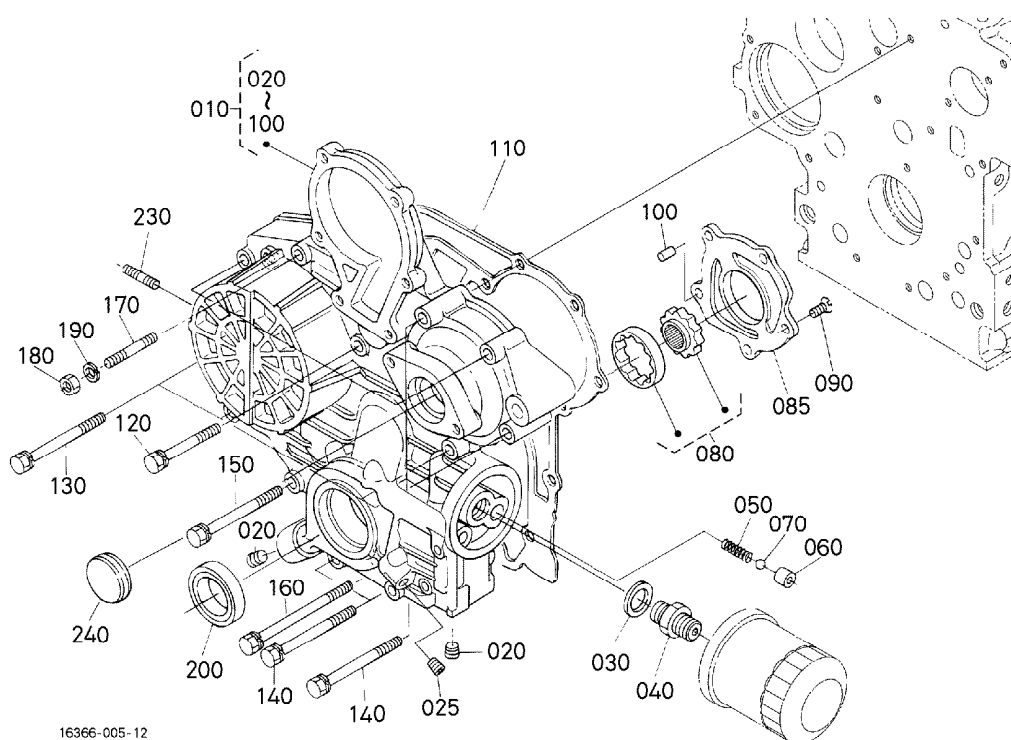

A: V1505-EB-HAYTER-1

REF. No. POS. No. BILD-Nr.	PART No. REFERENCE BESELL-Nr.	PART NAME	DESIGNATION	BEZEICHNUNG	QTY/S. No. QTE/No. S. STUECK/S. Nr.		I. C.	REMARKS REMARQUES BEMERKUNGEN
					A	B		
010	16251-0402-7	COMP. CASE, GEAR	CARTER DISTR. COMP.	KMP. GETRIEBEGEHAEUSE	≤500157	-		
010	16252-0402-0	COMP. CASE, GEAR	CARTER DISTR. COMP.	KMP. GETRIEBEGEHAEUSE	≥5E0001	-	↔	
010	16252-0402-2	COMP. CASE, GEAR	CARTER DISTR. COMP.	KMP. GETRIEBEGEHAEUSE	≥500148	-	←	
020	16241-9602-0	PLUG	BOUCHON	STOPFEN	2	-		
025	15521-9602-0	PLUG	BOUCHON	STOPFEN	1	-		
030	04011-50180	WASHER, PLAIN	RONDELLE FREIN	SCHEIBE	1	-		
040	15241-3229-0	JOINT, PIPE	RACCORD DE TUYAU	VERBINDUNGSSTUECK	1	-		
050	16241-3695-0	SPRING	RESSORT	FRUEHLING	1	-		
060	16241-3693-0	SEAT, VALVE	SIEGE DE SOUPEPE	SITZ, VENTIL	1	-		
070	07715-00201	BALL	BILLE	KUGEL	1	-		
080	16241-3507-0	ASSY ROTOR, OIL PUMP	ROTOR DE POMPE HUILE	OLFORORDERPUMPE LAUFER	1	-		
085	16251-3513-0	COVER, OIL PUMP	COUV. POMPE A HUILE	OELPUMPEDECKEL	1	-		
090	03017-50620	SCREW, CR-REC-BD-HD	VIS	SCHRAUBE	5	-		
100	05012-00410	PIN, STRAIGHT	GOUPILLE CYLINDRIQUE	ZYLINDERSTIFT	2	-		
110	16264-0413-0	GASKET, GEAR CASE	JOINT	DICHTUNGGETRIEBEGEH.	1	-		
120	01023-50645	BOLT	VIS	BOLZEN	3	-		
130	01023-60650	BOLT	VIS	BOLZEN	4	-		
140	01023-50655	BOLT	VIS	BOLZEN	4	-		
150	01023-50665	BOLT	VIS	BOLZEN	1	-		
160	16241-9104-0	BOLT	VIS	BOLZEN	1	-		
170	16245-9153-0	STUD	GOUJON	STEBBOLZEN	1	-		
180	02056-50060	NUT	ECROU	MUTTER	1	-		
190	04512-60060	WASHER, SPRING	RONDELLE GROWER	FEDERRING	1	-		
200	16241-0421-2	SEAL, OIL	BAGUE JOINT	OELDICHTUNGSRING	1	-		
210	----	BLANK	BLANC	LEERE SPALTE	-	-		
220	----	BLANK	BLANC	LEERE SPALTE	-	-		
230	16245-9154-0	STUD	GOUJON	STEBBOLZEN	2	-		
240	16264-8334-2	COVER, GEAR CASE	COUV. CARTER DISTRIB	DECKEL, GETRIEBEGEHAEUS	1	-		

↔ Interchangeable; ≠ not interchangeable; ← new for old; → old for new

0005

HEAD COVER
COUVRE-CULASSE
ZYLINDERKOPF-DECKEL

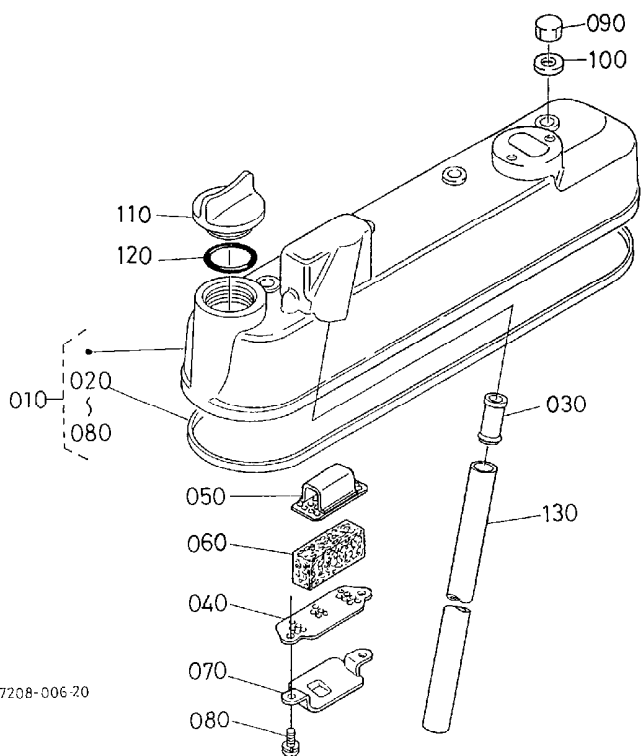

17208-006-20

A: V1505-EB-HAYTER-1

REF. No. POS. No. BILD-Nr.	PART No. REFERENCE BESELL-Nr.	PART NAME	DESIGNATION	BEZEICHNUNG	QTY/S. No. QTE/No. S. STUECK/S. Nr.		I. C.	REMARKS REMARQUES BEMERKUNGEN
					A	B		
010	16241-1450-0	ASSY COVER, CYL. HEAD	ENS. COUVERCLE	ZYLINDERKOPFHAUBE	1	-		
020	16241-1452-0	GASKET, HEAD COVER	JOINT COUVRE-CULASSE	DICHTUNG, KOPFDECKEL	1	-		
030	16241-0555-0	JOINT, BREATHER PIPE	RACCORD D'ASPI-TUYAU	ANSCHLUSSTEIL	1	-		
040	16241-0514-0	PLATE, B/THER ELEMENT	PLAQUE D'ELEMENT	PLATTE, ELEMENT	1	-		
050	16241-0515-0	PLATE, B/THER ELEMENT	PLAQUE D'ELEMENT	PLATTE, ELEMENT	1	-		
060	16241-0567-0	ELEMENT, BREATHER	TAMIS DU RENIFLARD	ENTLUEFTUNGSELEMENT	1	-		
070	16241-0537-0	OIL SHIELD, BREATHER	BOUCLIER, HUILE	OELSCHILD, ENTLUEFTER	1	-		
080	03024-50510	SCREW, WITH WASHER	VIS	SCHRAUBE	2	-		
090	15952-9233-0	NUT	ECROU	MUTTER	4	-		
100	15951-9666-0	GASKET	JOINT	DICHTUNGSPLATTE	4	-		
110	E9151-3314-0	PLUG, OIL FILLER	BOUCHON, REMPLIS. H/L	OELINFUELLSSTOPFEN	1	-		
120	04814-50300	O RING	JOINT TORIQUE	O RING	1	-		
130	16241-0551-0	PIPE, BREATHER	TUYAU DE RENIFLARD	ENTLUFTUNGSROHR	1	-		

↔ Interchangeable; ≠ not interchangeable; ← new for old; → old for new

0006 **OIL FILTER**
FILTRE D' HUILE
OELFILTER

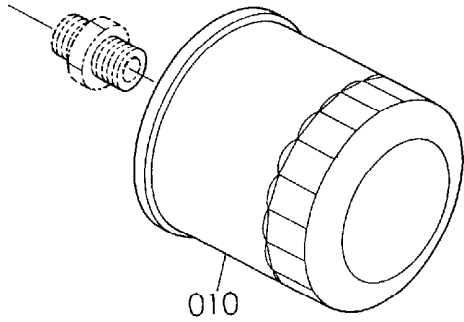

16615-003-10

A: V1505-EB-HAYTER-1

REF. No. POS. No. BILD-Nr.	PART No. REFERENCE BESELL-Nr.	PART NAME	DESIGNATION	BEZEICHNUNG	QTY/S. No. QTE/No. S. STUECK/S. Nr.		I. C.	REMARKS REMARQUES BEMERKUNGEN
					A	B		
010	16271-3209-2	ASSY CARTRIDGE OIL	ENS. CART. D' HUILE	MONTAGE, ZUSAMMENBAU	1	-		

↔ Interchangeable; ≠ not interchangeable; ← new for old; → old for new

0100

MAIN BEARING CASE PALIERS DE VILEBREQUIN HAUPTLAGERGEHAEUSE

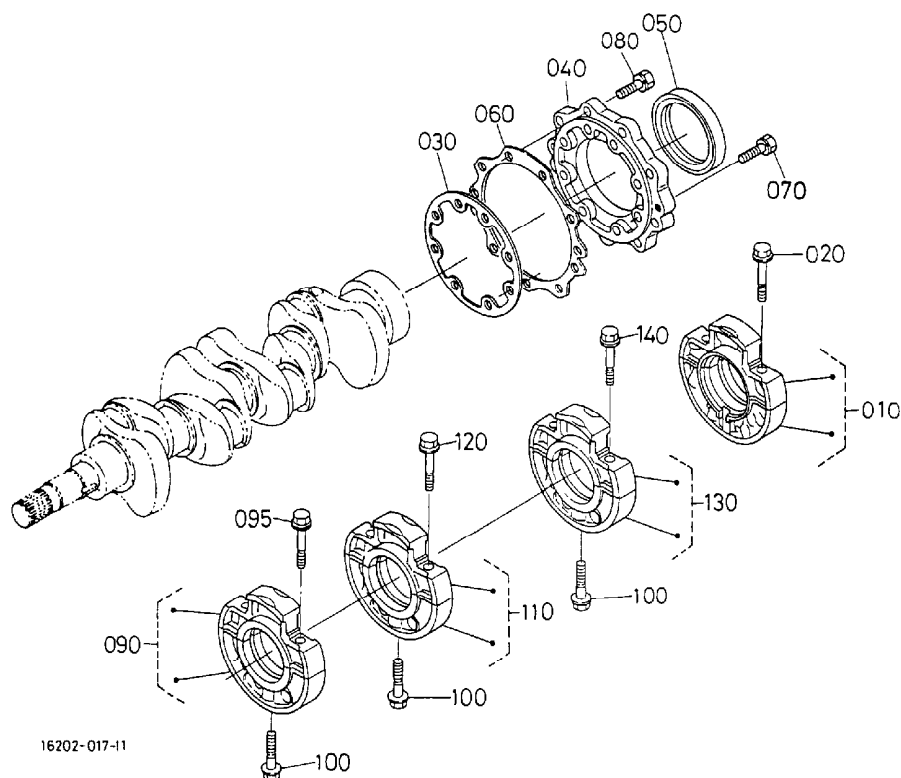

16202-017-11

A: V1505-EB-HAYTER-1

REF. No. POS. No. BILD-Nr.	PART No. REFERENCE BESELL-Nr.	PART NAME	DESIGNATION	BEZEICHNUNG	QTY/S. No. QTE/No. S. STUECK/S. Nr.		I. C.	REMARKS REMARQUES BEMERKUNGEN
					A	B		
010	16241-0409-2	ASSY CASE, MAIN BRG.	ENS. PALIER VILEBREQ.	GRP. LAGERGEHAEUSE	1	-		
020	16241-0454-0	BOLT, BEARING CASE	VIS	BOLZEN, LAGERKASTEN	2	-		
030	16264-0436-0	GASKET, BRG. CASE	JOINT	DICHTUNG, LAGER	1	-		
040	16241-0481-3	COVER, BEARING CASE	PORTE JOINT	DECKEL, LAGERKASTEN	1	-		
050	16241-0446-0	SEAL, OIL	BAGUE JOINT	OELDICHTUNGSRING	1	-		
050	16285-0446-0	SEAL, OIL	BAGUE JOINT	DEL DICHTUNGSRING	1	-	←	
060	16264-0482-0	GASKET	JOINT	DICHTUNGSPLATTE	1	-		
070	01023-50625	BOLT	VIS	BOLZEN	8	-		
080	01023-50620	BOLT	VIS	BOLZEN	9	-		
090	16261-0404-0	ASSY CASE, MAIN BRG.	ENS. PALIER VILEBREQ.	GRP. LAGERGEHAEUSE	1	-		
095	16241-0454-0	BOLT, BEARING CASE	VIS	BOLZEN, LAGERKASTEN	2	-		
100	16241-0456-0	BOLT, BEARING CASE	VIS	BOLZEN, LAGERKASTEN	3	-		
110	16261-0405-0	ASSY CASE, MAIN BRG.	ENS. PALIER VILEBREQ.	GRP. LAGERGEHAEUSE	1	-		
120	16241-0454-0	BOLT, BEARING CASE	VIS	BOLZEN, LAGERKASTEN	2	-		
130	16282-0406-0	ASSY CASE, MAIN BRG.	ENS. PALIER VILEBREQ.	GRP. LAGERGEHAEUSE	1	-		
140	16241-0454-0	BOLT, BEARING CASE	VIS	BOLZEN, LAGERKASTEN	2	-		

↔ Interchangeable; ≠ not interchangeable; ← new for old; → old for new

0101

CAMSHAFT AND IDLE GEAR SHAFT
 ARBRE A CAMES ET ARBRE DE PIGNON DE RALENTI
 NOCKENWELLE UND FREILAUFGETRIEBEWELLE

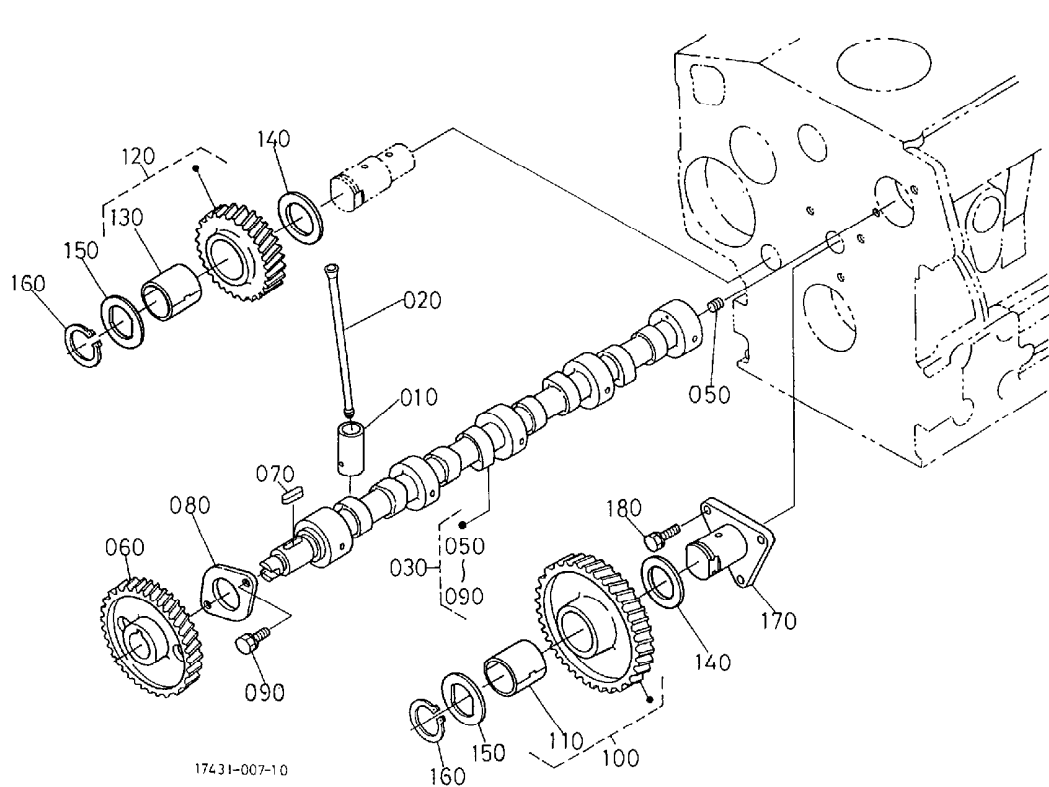

17431-007-10

A: V1505-EB-HAYTER-1

REF. No. POS. No. BILD-Nr.	PART No. REFERENCE BESELL-Nr.	PART NAME	DESIGNATION	BEZEICHNUNG	QTY/S. No. Q' TE/No. S. STUECK/S. Nr.		I. C.	REMARKS REMARQUES BEMERKUNGEN
					A	B		
010	16261-1555-0	TAPPET	POUSSOIR	STOSSEL	8	-		
020	16241-1511-0	PUSH ROD	TIGE DE POUSSOIR	STOSSELSTANGE	8	-		
030	16271-1601-0	ASSY CAMSHAFT	ENS. ARBRE A CAMES	GRP. NOCKENWELLE	1	-		
030	16271-1691-0	ASSY CAMSHAFT	ENS. ARBRE A CAMES	GRP. NOCKENWELLE	≤=4M0019	-		
040	----	BLANK	BLANC	LEERE SPALTE	1	-	←	
050	15521-9361-0	SCREW, SET	VIS D' ARRET	ANSCHLAGSCHRAUBE	1	-		
060	16241-1651-0	GEAR, CAM	PIGNON	ZAHNRAD	1	-		
070	05712-00518	KEY, FEATHER	CLAVETTE	KEIL	1	-		
080	16241-1627-0	STOPPER, CAMSHAFT	BOUCHON ARBRE A CAME	NOCKENWELLESPERRPLA.	1	-		
090	01023-50616	BOLT	VIS	BOLZEN	2	-		
100	16271-2401-0	COMP GEAR, IDLE	PIGNON. COMP	KOMP. LEERLAUFGETRIEB	1	-		
110	16271-2498-0	BUSH, IDLE GEAR	BAGUE DU PIGNON	BUCHSE, LEERLAUFGETR.	1	-		
120	16271-2402-0	COMP GEAR, IDLE	PIGNON. COMP	KOMP. LEERLAUFGETRIEB	1	-		
130	16271-2498-0	BUSH, IDLE GEAR	BAGUE DU PIGNON	BUCHSE, LEERLAUFGETR.	1	-		
140	16241-2436-0	COLLAR, IDLE GEAR	COLLIER DE PIGNONF.	HUELSELEERLAUFGETRI.	2	-		
150	16241-2437-0	COLLAR, IDLE GEAR	COLLIER DE PIGNONF.	HUELSELEERLAUFGETRI.	2	-		
160	16241-2432-0	CIR CLIP, IDLE GEAR	CIRCLIP	SEEGERING	2	-		
170	16241-2425-0	SHAFT, IDLE GEAR	ARBRE DE PIGNON FOU	WELLE, FREILAUFGETR.	1	-		
180	01023-50616	BOLT	VIS	BOLZEN	3	-		

↔ Interchangeable; ≠ not interchangeable; ← new for old; → old for new

0102

**PISTON AND CRANKSHAFT
PISTON ET VILEBREQUIN
KOLBEN UND KURBELWELLE**

NOTE: ORDER BY REF. No. 010 and 020 +0.5mm NEW PARTS

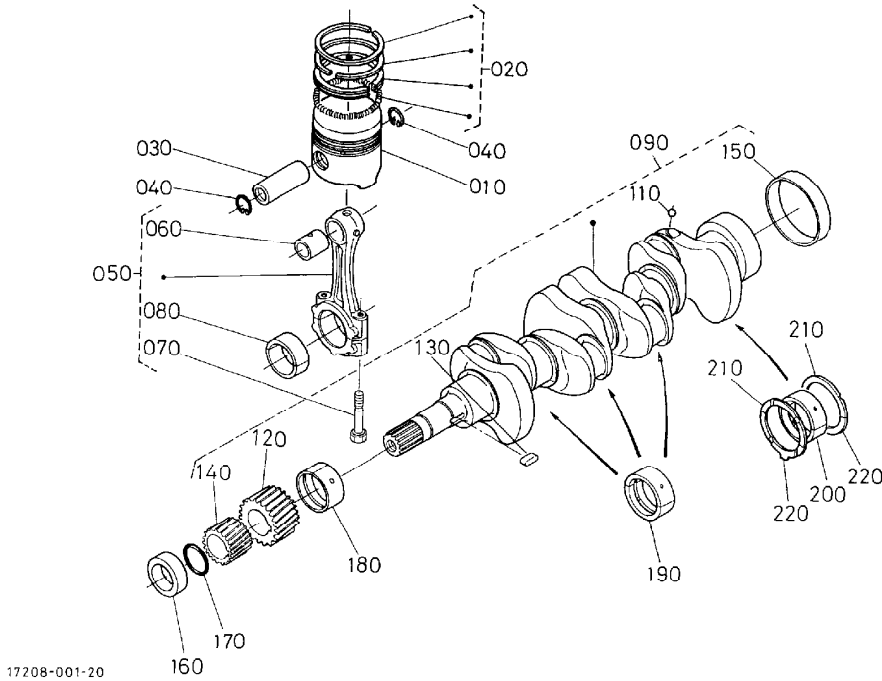

A: V1505-EB-HAYTER-1

REF. No. POS. No. BILD-Nr.	PART No. REFERENCE BESELL-Nr.	PART NAME	DESIGNATION	BEZEICHUNG	QTY/S. No. Q' TE/No. S. STUECK/S. Nr.		I. C.	REMARKS REMARQUES BEMERKUNGEN
					A	B		
010	16060-2111-0	PISTON	PISTON	KOLBEN	4 ≤5FQ181	-		STD
010	16060-2111-3	PISTON	PISTON	KOLBEN	4 ≥5G0001	-	≠	STD
010	16060-2111-4	PISTON	PISTON	KOLBEN	4 ≥5W0009	-	←	STD
010	16060-2191-0	PISTON	PISTON	KOLBEN	4 ≤5FQ181	-		+0.5mm NOT SALE, SEE NOTE
010	16060-2191-3	PISTON	PISTON	KOLBEN	4 ≥5G0001	-	≠	+0.5mm
010	16060-2191-4	PISTON	PISTON	KOLBEN	4 ≥5W0009	-	←	+0.5mm
020	16261-2105-0	ASSY PISTON RING	ENS. SEGMENT	GRP. KOLBENRING	4 ≤5FQ181	-		STD
020	16292-2105-0	ASSY PISTON RING	ENS. SEGMENT	GRP. KOLBENRING	4 ≥5G0001	-	≠	STD
020	16261-2109-0	ASSY PISTON RING	ENS. SEGMENT	GRP. KOLBENRING	4 ≤5FQ181	-		+0.5mm
020	16292-2109-0	ASSY PISTON RING	ENS. SEGMENT	GRP. KOLBENRING	4 ≥5G0001	-	≠	+0.5mm
030	16241-2131-0	PIN, PISTON	AXE DE PISTON	KOLBENBOLZEN	4	-		
040	16241-2133-0	CIR CLIP, PISTON PIN	CIRCLIP	SEEGERING	8	-		
050	16241-2201-2	ASSY ROD, CONNECTING	ENS. BIELLE	TRIEBSTANGE KOMP	4	-		
060	16241-2198-2	BUSH, PISTON PIN	BAGUE DE BIELLE	BUCHSE, KOLBENSTIFT	4	-		
070	16241-2214-2	BOLT, CONNECTING ROD	VIS DE BIELLE	BOLZEN	8	-		
080	16241-2231-0	METAL, CRANKPIN	COUSSINET DE BIELLE	METALLTEIL	4	-		STD SET
080	16241-2297-0	METAL, CRANKPIN	COUSSINET DE BIELLE	METALLTEIL	4	-		+0.2mm SET
080	16241-2298-0	METAL, CRANKPIN	COUSSINET DE BIELLE	METALLTEIL	4	-		+0.4mm SET
090	16282-2301-3	COMP. CRANKSHAFT	VILEBREQUIN COMPLET	KOMP. KURBELWELLE	1	-		
100	----	BLANK	BLANC	LEERE SPALTE	-	-		
110	07715-00401	BALL	BILLE	KUGEL	4	-		
120	16241-2411-0	GEAR, CRANK	PIGNON	ZAHNRAD	1	-		
130	16271-9523-0	KEY	CLAVETTE	KEIL	1	-		
140	16241-3563-0	GEAR, OIL PUMP DRIVE	PIGNON ENTRAIN. POMPE	GETRIEBE	1	-		
150	16241-2328-0	SLEEVE, CRANKSHAFT	FRETTE ARRIERE	MUFFE	1	-		
160	16241-2325-0	COLLAR, CRANKSHAFT	COLLIER VILEBREQUIN	HALSRING	1	-		
170	04814-10280	RING	BAGUE	RING	1	-		
180	16241-2347-0	METAL, CRANKSHAFT	COUSSINET DE VILEBR.	METALLTEIL	1	-		STD
180	16241-2391-0	METAL, CRANKSHAFT	COUSSINET DE VILEBR.	METALLTEIL	1	-		-0.2mm
180	16241-2392-0	METAL, CRANKSHAFT	COUSSINET DE VILEBR.	METALLTEIL	1	-		-0.4mm

↔ Interchangeable; ≠ not interchangeable; ← new for old; → old for new

**0103 FLYWHEEL
VOLANT MOTEUR
SCHWUNGRAD**

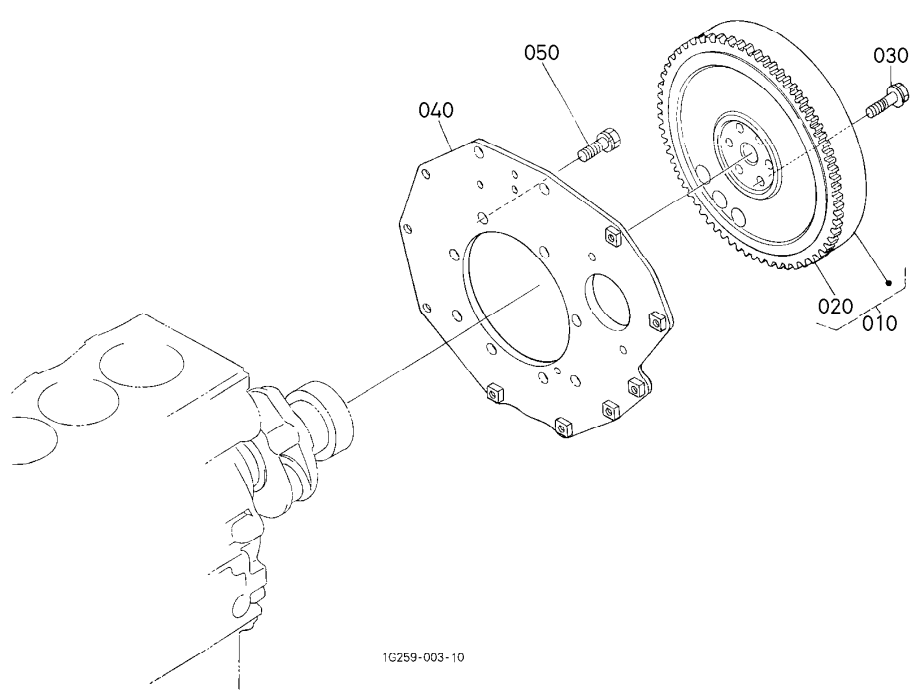

A:V1505-EB-HAYTER-1

REF. No. POS. No. BILD-Nr.	PART No. REFERENCE BESELL-Nr.	PART NAME	DESIGNATION	BEZEICHNUNG	QTY/S. No.		I. C.	REMARKS REMARKES BEMERKUNGEN
					QTY/S. No. STUECK/S. Nr.	QTY/S. No. STUECK/S. Nr.		
					A	B		
010	16614-2501-2	COMP. FLYWHEEL	VOLANT MOTEUR COMP.	KOMP. SCHWUNGRAD	1	-		
020	16813-6382-0	GEAR RING	COURONNE DE DEMARRE.	ZAHNKRANZ	1	-		
030	16241-2516-0	BOLT, FLYWHEEL	VIS DE VOLANT	BOLZEN, SCHWUNGRAD	6	-		
040	16241-0462-0	PLATE, REAR END	PLAQUE ARRIERE-TRAIN	PLATTE	1	-		
050	15261-9119-0	BOLT	VIS	BOLZEN	8	-		

0105

FUEL CAMSHAFT AND GOVERNOR SHAFT
 ARBRE A CAMES DE CARBURANT ET ARBRE REGULATEUR
 KRAFTSTOFF-NOCKENWELLE UND ACHSE

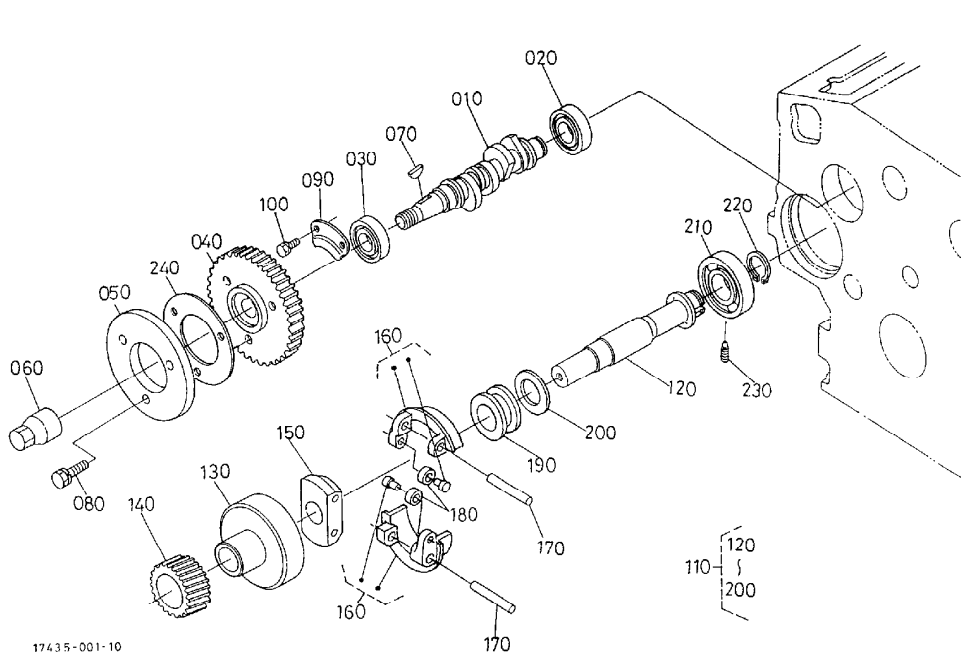

174.35-001-10

A:V1505-EB-HAYTER-1

REF. No. POS. No. BILD-Nr.	PART No. REFERENCE BESELL-Nr.	PART NAME	DESIGNATION	BEZEICHNUNG	Q' TY/S. No. Q' TE/No. S. STUECK/S. Nr.		I. C.	REMARKS REMARQUES BEMERKUNGEN
					A	B		
010	16040-1617-0	CAMSHAFT, FUEL	ARBRE A CAMES	NOCKENWELLE	1	-		
020	16261-9730-0	BEARING, BALL	ROULEMENT A BILLES	KUGELLAGER	1	-		
030	16261-9731-0	BEARING, BALL	ROULEMENT A BILLES	KUGELLAGER	1	-		
040	16272-5115-0	GEAR, INJECTION PUMP	ENGR. POMPE D' INJEC.	GETRIEBEZAHNRAD	1	-		
050	16241-5111-3	CAM, FUEL	CAME DE CARBURANT	NOCKEN	1	-		
060	16241-9233-0	NUT	ECROU	MUTTER	1	-		
070	16241-9523-0	KEY, WOODRUFF	CLAVETTE WOODRUFF	SCHEIBEN-KEIL	1	-		
080	01023-50618	BOLT	VIS	BOLZEN	3	-		
090	16241-1632-0	STOPPER, FUEL. C/SHAFT	BOUCHON	STOPFENNOCKENWELLE	1	-		
100	01023-50616	BOLT	VIS	BOLZEN	2	-		
110	16271-5501-3	ASSY SHAFT, GOVERNOR	ENS. ARBRE REGULATE.	GRP. ACHSE	1	-		
120	16271-5531-3	SHAFT, GOVERNOR	ARBRE DE REGULATEUR	REGLERWELLE	1	-		
130	16241-5539-2	HOLDER, GOVERNOR GEAR	SUPPORT REGUL-PIGNON	HALTER	1	-		
140	16271-5532-0	GEAR, GOVERNOR	ENGRENAGE DE REGULAT	REGELERZAHNRAD	1	-		
150	16241-5527-0	HOLDER, GOV. WEIGHT	SUPPORT POIDS REGUL.	HALTER, GEWICHT	1	-		
160	16271-5506-0	COMP. WEIGHT, GOVERNOR	POIDS COMP. REGUL.	GEWICHT KOMP.	2	-		
170	16241-5526-0	SHAFT, GOV. WEIGHT	ARBRE DE POIDS REG.	WELLE	2	-		
180	19484-5544-0	ROLLER	ROULEAU	ROLLE	2	-		
190	16241-5545-0	SLEEVE, GOVERNOR	BAGUE DE REGULATEUR	REGLERMUFFE	1	-		
200	16241-5546-3	WASHER, THRUST	RONDELLE DE BUTEE	DRUCKSCHEIBE	1	-		
210	16261-9732-0	BEARING, BALL	ROULEMENT A BILLES	KUGELLAGER	1	-		
220	16271-5541-0	CIR CLIP, GOV. SHAFT	CIRCLIP DE REG. ARBRE	SPRENGRING	1	-		
230	16241-5555-4	SCREW, SET	VIS D' ARRET	ANSCHLAGSCHRAUBE	1	-		
240	16241-5119-0	WASHER	RONDELLE	SCHEIBE	1	-		

↔ Interchangeable; ≠ not interchangeable; ← new for old; → old for new

0180

IDLE APPARATUS DISPOSITIF DE RALENTISSEUR FREILAUFAPPARAT

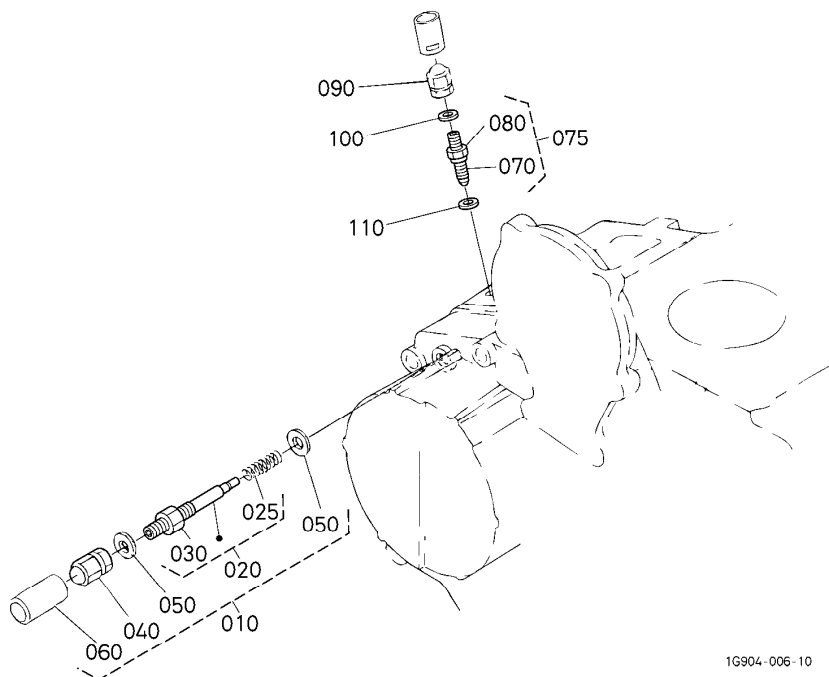

1G904-006-10

A: V1505-EB-HAYTER-1

REF. No. POS. No. BILD-Nr.	PART No. REFERENCE BESELL-Nr.	PART NAME	DESIGNATION	BEZEICHNUNG	Q' TY/S. No. Q' TE/No. S. STUECK/S. Nr.		I. C.	REMARKS REMARQUES BEMERKUNGEN
					A	B		
010	16285-5409-3	APPARATUS, IDLING	DISPOSITIF DE RALENT	BAUTEIL, FREILAF-APPA	1	-		
020	16285-5410-3	ASSY BOLT, ADJUSTMENT	ENS. BOULON AU POINT	GRP. BOLZENFEINEINST.	1	-		
025	16285-5426-0	SPRING	RESSORT	FEDER	1	-		NOT SALE
030	15841-9202-0	NUT	ECROU	MUTTER	1	-		
040	15852-9233-0	NUT	ECROU	MUTTER	1	-		
050	15601-9665-0	GASKET	JOINT	DICHTUNGSPLATTE	2	-		
060	16221-5442-0	CAP	BOUCHON	KAPPE	1	-		
070	16241-5412-2	BOLT, ADJUSTING	VIS REGLAGE	EINSTELBOLZEN	1	-		
075	1G032-5435-0	ASSY BOLT, ADJUSTMENT	ENS. BOULON AU POINT	GRP. BOLZENFEINEINST.	1	-		NOT SALE
080	1G031-5421-0	NUT, LOCK	CONTRE-ECROU	MUTTER	1	-		
090	15852-9233-0	NUT	ECROU	MUTTER	1	-		
100	15601-9665-0	GASKET	JOINT	DICHTUNGSPLATTE	1	-		
110	1G021-9665-0	GASKET	JOINT	DICHTUNGSPLATTE	1	-		

↔ Interchangeable; ≠ not interchangeable; ← new for old; → old for new

0201

STOP SOLENOID SOLENOÏDE D' ARRET ABSTELLSOLENOID

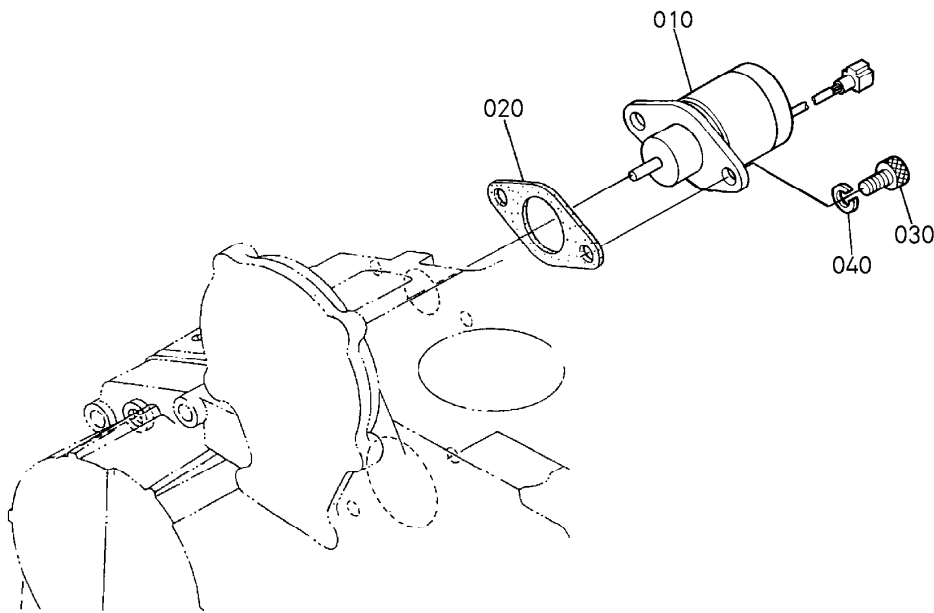

16225-039-12

OLD PARTS

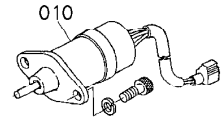

16225-827-10

A:V1505-EB-HAYTER-1

REF. No. POS. No. BILD-Nr.	PART No. REFERENCE BESELL-Nr.	PART NAME	DESIGNATION	BEZEICHNUNG	Q'TY/S.No. Q'TE/No.S. STUECK/S.Nr.		I. C.	REMARKS REMARQUES BEMERKUNGEN
					A	B		
010	16259-6001-0	ASSY SOLENOID	ENS. SOLENOID	DRAHTSPULE, KOMP	1	-		
010	17208-6001-0	ASSY SOLENOID, STOP	ENS. SOLENOÏDE	DRAHTSPULE, KOMP	1	-	≠	
020	16299-6015-0	GASKET	JOINT	DICHTUNGSPLATTE	1	-		
030	01311-10614	BOLT, HEX-SOC-HD	VIS	BOLZEN	2	-		
040	04512-60060	WASHER, SPRING	RONDELLE GROWER	FEDERRING	2	-		

↔ Interchangeable; ≠ not interchangeable; ← new for old; → old for new

0202

INJECTION PUMP POMPE D' INJECTION EINSPRITZENPUMPE

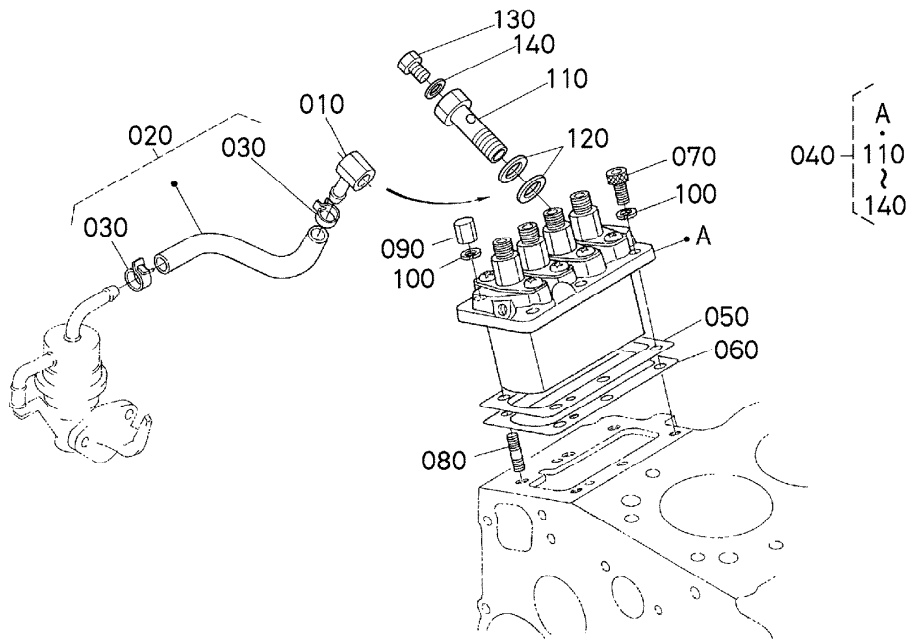

16615-011-13

A: V1505-EB-HAYTER-1

REF. No. POS. No. BILD-Nr.	PART No. REFERENCE BESELL-Nr.	PART NAME	DESIGNATION	BEZEICHNUNG	QTY/S. No.		I. C.	REMARKS REMARQUES BEMERKUNGEN
					QTY/S. No. STUECK/S. Nr.	A		
010	16241-9569-0	JOINT, EYE	RACCORD	VERBINDUNGSTUECK	1	-		
020	16241-4201-0	ASSY PIPE, FUEL	ENS. TUYAU CARBURANT	GRP. KRAFTSTOFFROHR	1	-		
030	14911-4275-0	CLIP, PIPE	ATTACHE	ROHRKLEMME	2	-		
040	16060-5101-0	ASSY PUMP, INJECTION	ENS. POMPE INJECTION	GRP. EINSPRITZPUMPE	1	-		
050	16040-5209-2	SHIM, INJECTION PUMP	CALE, POMPE INJECTION	ABSTANDSSCHEIBE	1	-		0. 20mm
050	16040-5211-2	SHIM, INJECTION PUMP	CALE, POMPE INJECTION	ABSTANDSSCHEIBE	1	-		0. 25mm
060	16040-5212-2	SHIM, INJECTION PUMP	CALE, POMPE INJECTION	ABSTANDSSCHEIBE	1	-		0. 30mm
070	01311-10620	BOLT, HEX-SOC-HD	VIS	BOLZEN	3	-		
080	15841-9150-0	STUD	GOUJON	STEBOLZEN	3	-		
090	15841-9232-0	NUT	ECROU	MUTTER	3	-		
100	04512-60060	WASHER, SPRING	RONDELLE GROWER	FEDERRING	6	-		
110	16030-5132-0	BOLT, JOINT	VIS	BOLZEN, ABSCHLUSS	1	-		
120	15841-9665-0	GASKET	JOINT	DICHTUNGSPLATTE	2	-		
130	15841-5135-0	SCREW	VIS	SCHRAUBE	1	-		
140	15841-9666-0	GASKET	JOINT	DICHTUNGSPLATTE	1	-		

↔ interchangeable; ≠ not interchangeable; ← new for old; → old for new

0205

SPEED CONTROL PLATE PLAQUE DE VITESSE-CONTROLE GESCHWINDIGKEITS-REGLERPLATTE

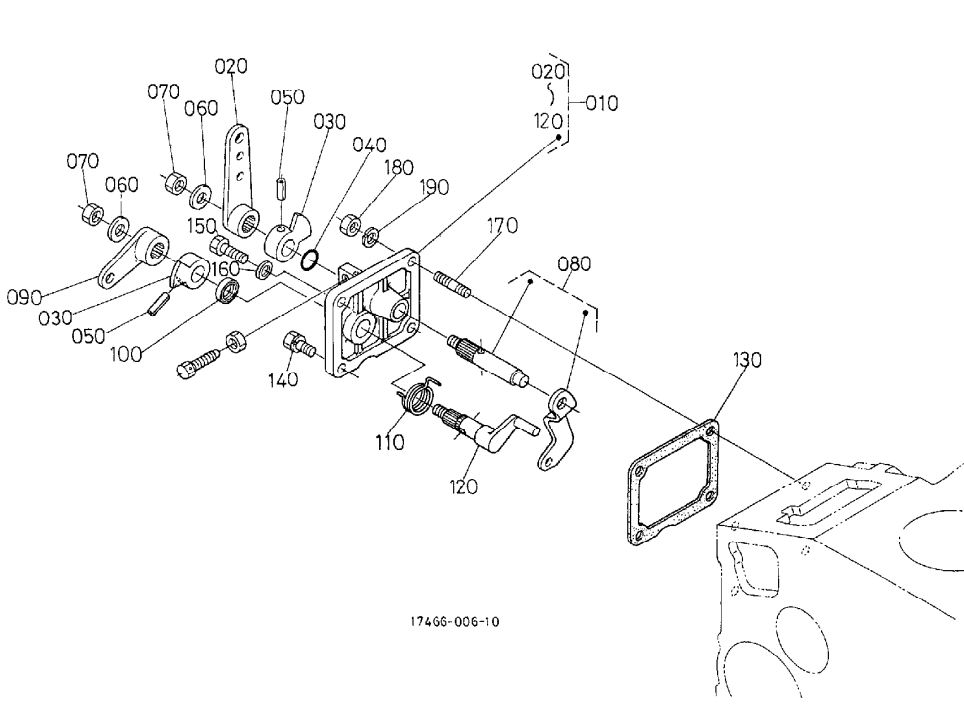

A:V1505-EB-HAYTER-1

REF. No. POS. No. BILD-Nr.	PART No. REFERENCE BESELL-Nr.	PART NAME	DESIGNATION	BEZEICHNUNG	Q' TY/S. No. Q' TE/No. S. STUECK/S. Nr.		I. C.	REMARKS REMARQUES BEMERKUNGEN
					A	B		
010	16299-5701-5	ASSY PLATE, CONTROL	PLATEAU DE COMMANDE	GRP. REGELPLATTE	1	-		
020	16271-5715-0	LEVER, SPEED CONTROL	LEVIER DE VIT-CONTRO	DREHZAHLVERSTELHEBEL	1	-		
030	16241-5716-0	LEVER, SPEED CONTROL	LEVIER DE VIT-CONTRO	DREHZAHLVERSTELHEBEL	2	-		
040	04814-00100	O RING	JOINT TORIQUE	O RING	1	-		
050	05411-00420	PIN, SPRING	GOUPILLE-RESSORT	STIFT, FEDR	2	-		
060	16241-9402-0	WASHER, PLAIN	RONDELLE FREIN	SCHEIBE	2	-		
070	16241-9202-0	NUT	ECROU	MUTTER	2	-		
080	16271-5602-3	COMP. LEVER, GOVERNOR	AXE D' ACCELERATEUR	KOMP. REGLERHEBEL	1	-		
090	16271-5772-0	LEVER, ENGINE STOP	LEVIER D' ARRET	MOTOR-STOPHEBEL	1	-		
100	15471-5798-0	SEAL, OIL	BAGUE JOINT	OELDICHTUNGSRING	1	-		
110	16222-5751-0	SPRING, RETURN	RESSORT DE RAPPEL	RUECKZUGFEDER	1	-		
120	16271-5774-0	SHAFT, STOP LEVER	ARBRE D' ARRET-LEVIER	WELLE	1	-		
130	16264-5721-0	GASKET	JOINT	DICHTUNGSPLATTE	1	-		
140	01023-50616	BOLT	VIS	BOLZEN	1	-		
150	01053-50618	BOLT	VIS	BOLZEN	1	-		
160	15601-9665-0	GASKET	JOINT	DICHTUNGSPLATTE	1	-		
170	16245-9154-0	STUD	GOUJON	STEBOLZEN	2	-		
180	02056-50060	NUT	ECROU	MUTTER	2	-		
190	04512-60060	WASHER, SPRING	RONDELLE GROWER	FEDERRING	2	-		

↔ Interchangeable; ≠ not interchangeable; ← new for old; → old for new

0206

NOZZLE HOLDER AND GLOW PLUG
 PORTE-INJECTEUR ET BOUGIE DE PRECHAUFFAGE
 DUESENHALTER UND GLUEHKERZE

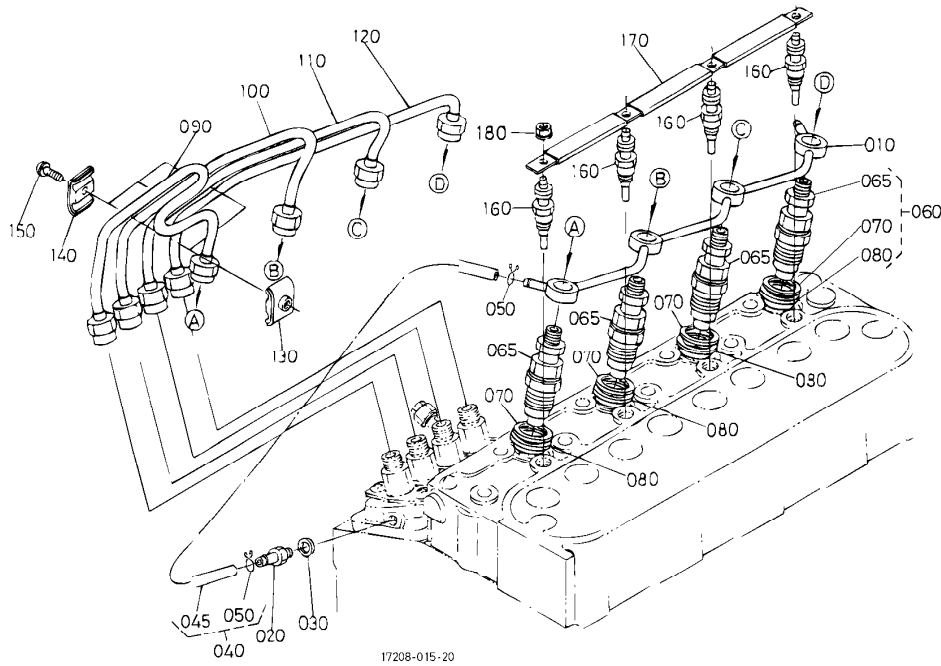

A: V1505-EB-HAYTER-1

REF. No. POS. No. BILD-Nr.	PART No. REFERENCE BESELL-Nr.	PART NAME	DESIGNATION	BEZEICHNUNG	Q' TY/S. No. Q' TE/No. S. STUECK/S. Nr.		I. C.	REMARKS REMARQUES BEMERKUNGEN
					A	B		
010	16271-4250-2	ASSY PIPE, OVER FLOW	ENS. TUYAU TROP-PLEIN	GRP. UEBERLAUFROHR	1	-		
020	15841-5136-0	SCREW, AIR BREEDER	VIS DE AIR-AVICLTEUR	SCHRAUBE	1	-		
030	15601-9665-0	GASKET	JOINT	DICHTUNGSPLATTE	1	-		
040	15841-4250-0	ASSY PIPE, OVER FLOW	ENS. TUYAU TROP-PLEIN	GRP. UEBERLAUFROHR	1	-		
045	15841-4252-0	PIPE, FUEL OVER FLOW	TUYAU DE TROP-PLEIN	KRAFTSTOFFU-LAUFROHR	1	-		
050	14971-4275-0	CLIP, PIPE	ATTACHE	ROHRKLEMME	2	-		
060	16032-5390-0	KIT HOLDER, NOZZLE	ENS. PORTE-INJECTEUR	GRP. DUESENHALTER	4	-		
065	16032-5300-0	ASSY HOLDER, NOZZLE	ENS. PORTE-INJECTEUR	GRP. DUESENHALTER	4	-		
070	15841-5362-2	GASKET	JOINT	DICHTUNGSPLATTE	4	-		
080	19077-5365-0	SEAL, HEAT	JOINT DE CHALEUR	DICHTUNG	4	-		
090	16271-5371-2	PIPE, INJECTION	TUYAU D' INJECTEUR	EINSPRITZROHR	1	-		
100	16271-5372-2	PIPE, INJECTION	TUYAU D' INJECTEUR	EINSPRITZROHR	1	-		
110	16271-5373-2	PIPE, INJECTION	TUYAU D' INJECTEUR	EINSPRITZROHR	1	-		
120	16271-5374-2	PIPE, INJECTION	TUYAU D' INJECTEUR	EINSPRITZROHR	1	-		
130	15841-5385-0	CLAMP, PIPE	COLLIER DE TUYAU	ROHRKLEMME	3	-		
140	15841-5386-0	CLAMP, PIPE	COLLIER DE TUYAU	ROHRKLEMME	3	-		
150	03024-50520	SCREW, WITH WASHER	VIS	SCHRAUBE	3	-		
160	16851-6551-2	GLOW PLUG	BOUGIE, PRE-CHAUFFAGE	GLUEHSTOEPEL	4	-		
170	16271-6556-0	CORD, GLOW PLUG	FILDEBOUG, PRECHAUFF.	GLUEHKERZEKORD	1	-		
180	02761-50040	NUT, FLANGE	ECROU A EMBASE	FLANSCHEN-MUTTER	4	-		

↔ Interchangeable; ≠ not interchangeable; ← new for old; → old for new

0207

NOZZLE HOLDER (COMPONENT PARTS)
 PORTE-INJECTEUR (PARTIES COMPOSANTES)
 DUESENHALTER (EINZEL-TEIL)

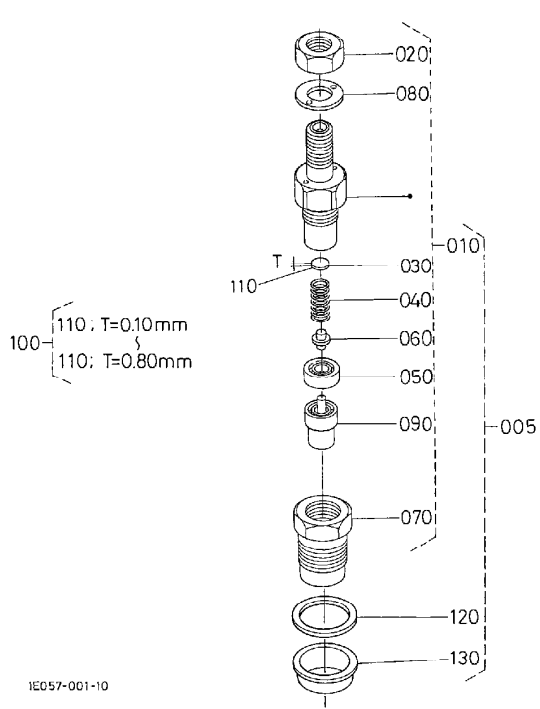

1E057-001-10

A:V1505-EB-HAYTER-1

REF. No. POS. No. BILD-Nr.	PART No. REFERENCE BESELL-Nr.	PART NAME	DESIGNATION	BEZEICHNUNG	Q'TY/S. No. Q'TE/No. S. STUECK/S. Nr.		I. C.	REMARKS REMARQUES BEMERKUNGEN
					A	B		
005	16032-5390-0	KIT HOLDER, NOZZLE	ENS. PORTE-INJECTEUR	GRP. DUESENHALTER	4	-		
010	16032-5300-0	ASSY HOLDER, NOZZLE	ENS. PORTE-INJECTEUR	GRP. DUESENHALTER	4	-		
020	16032-9203-0	NUT	ECROU	MUTTER	4	-		
030	16032-5323-0	WASHER, ADJUSTING	RONDELLE DE REGLAGE	EINSTELLSCHEIBE	4	-		
040	16032-5317-0	SPRING, NOZZLE	RESSORT D'INJECTEUR	FRUEHLING	4	-		
050	16032-5335-0	SPACER, DISTANCE	ENTRETOISE	DISTANZSCHEIBE	4	-		
060	16032-5316-0	PUSH ROD	TIGE DE POUSSOIR	STOSSELSTANGE	4	-		
070	16032-5328-0	NUT, NOZZLE	ECROU D'INJECTEUR	MUTTER	4	-		
080	16032-9404-0	WASHER, PLAIN	RONDELLE FREIN	SCHEIBE	4	-		
090	16032-5361-0	PIECE, NOZZLE	ELEMENT D'INJECTEUR	DUESENSTUECK	4	-		
100	16032-9810-0	ASSY WASHER, ADJUST	ENS. RONDELLE	GRP. EINSTELLSCHEIBE	4	-		OPTION
110	16032-9850-0	WASHER, ADJUSTING	RONDELLE DE REGLAGE	EINSTELLSCHEIBE	4	-		0. 10mm
110	16032-9851-0	WASHER, ADJUSTING	RONDELLE DE REGLAGE	EINSTELLSCHEIBE	4	-		0. 20mm
110	16032-9852-0	WASHER, ADJUSTING	RONDELLE DE REGLAGE	EINSTELLSCHEIBE	4	-		0. 30mm
110	16032-9853-0	WASHER, ADJUSTING	RONDELLE DE REGLAGE	EINSTELLSCHEIBE	4	-		0. 40mm
110	16032-9854-0	WASHER, ADJUSTING	RONDELLE DE REGLAGE	EINSTELLSCHEIBE	4	-		0. 50mm
110	16032-9855-0	WASHER, ADJUSTING	RONDELLE DE REGLAGE	EINSTELLSCHEIBE	4	-		0. 52mm
110	16032-9856-0	WASHER, ADJUSTING	RONDELLE DE REGLAGE	EINSTELLSCHEIBE	4	-		0. 54mm
110	16032-9857-0	WASHER, ADJUSTING	RONDELLE DE REGLAGE	EINSTELLSCHEIBE	4	-		0. 56mm
110	16032-9858-0	WASHER, ADJUSTING	RONDELLE DE REGLAGE	EINSTELLSCHEIBE	4	-		0. 58mm
110	16032-9859-0	WASHER, ADJUSTING	RONDELLE DE REGLAGE	EINSTELLSCHEIBE	4	-		0. 80mm
120	15841-5362-2	GASKET	JOINT	DICHTUNGSPLATTE	4	-		
130	19077-5365-0	SEAL, HEAT	JOINT DE CHALEUR	DICHTUNG	4	-		

↔ Interchangeable; ≠ not interchangeable; ← new for old; → old for new

0212

FORK LEVER (GOVERNOR) LEVIER A FOURCHE (REGULATEUR DE VITESSES) HEBEL-GABEL (REGLER)

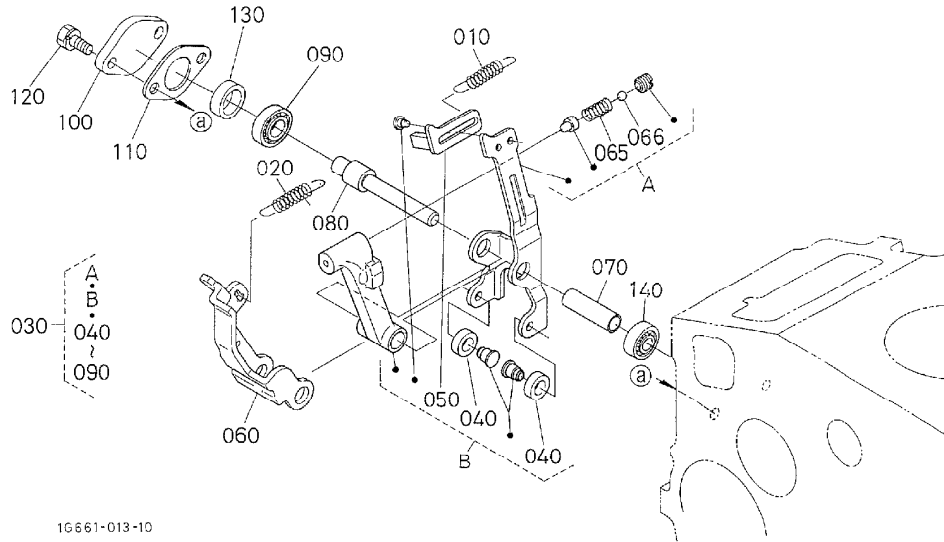

16661-013-10

A: V1505-EB-HAYTER-1

REF. No. POS. No. BILD-Nr.	PART No. REFERENCE BESELL-Nr.	PART NAME	DESIGNATION	BEZEICHNUNG	Q' TY/S. No. Q' TE/No. S. STUECK/S. Nr.		I. C.	REMARKS REMARQUES BEMERKUNGEN
					A	B		
010	16271-5648-0	SPRING, START	RESSORT DE SURCHARGE	STARTERFEDER	1	-		
020	16285-5641-2	SPRING, GOVERNOR	RESSORT DE REGULATEUR	REGLERFEDER	1	-		
030	1G069-5601-3	ASSY LEVER, FORK	ENS. LEVIER A FOURCHE	GRP. GABELHEBEL	1	-		
040	19484-5544-0	ROLLER	ROULEAU	ROLLE	2	-		
050	16271-5621-4	LEVER, THRUST	LEVIER DE BUTEE	GABELHEBEL	1	-		
060	1G032-5613-0	LEVER, FORK	LEVIER A FOURCHE	HEBEL, GABEL	1	-		
065	16060-5423-0	SPRING	RESSORT	FEDER	1	-		
066	07715-03205	BALL	BILLE	KUGEL	2	-		
070	1G032-5615-0	SHAFT, FORK LEVER	ARBRE DE FOUR-LEVIER	GABELHEBELWELLE	1	-		
080	1G032-5647-0	SHAFT, FORK LEVER	ARBRE DE FOUR-LEVIER	GABELHEBELWELLE	1	-		
090	16241-5633-0	BEARING, MINIATURIZE	ROULEMENT	KUGELLAGER	1	-		
100	16241-5625-0	COVER, FORK LEV. SHAFT	COUV. FOURCHE ARBRE	DECKEL	1	-		
110	16299-5626-0	GASKET	JOINT	DICHTUNG	1	-		
120	01023-50614	BOLT	VIS	BOLZEN	2	-		
130	16241-5621-0	COLLAR	COLLIER	HUELSE	1	-		
140	16241-5634-0	BEARING, MINIATURIZE	ROULEMENT	KUGELLAGER	1	-		

↔ Interchangeable; ≠ not interchangeable; ← new for old; → old for new

0300

FUEL FILTER FILTRE A CARBURANT KRAFTSTOFFFILTER

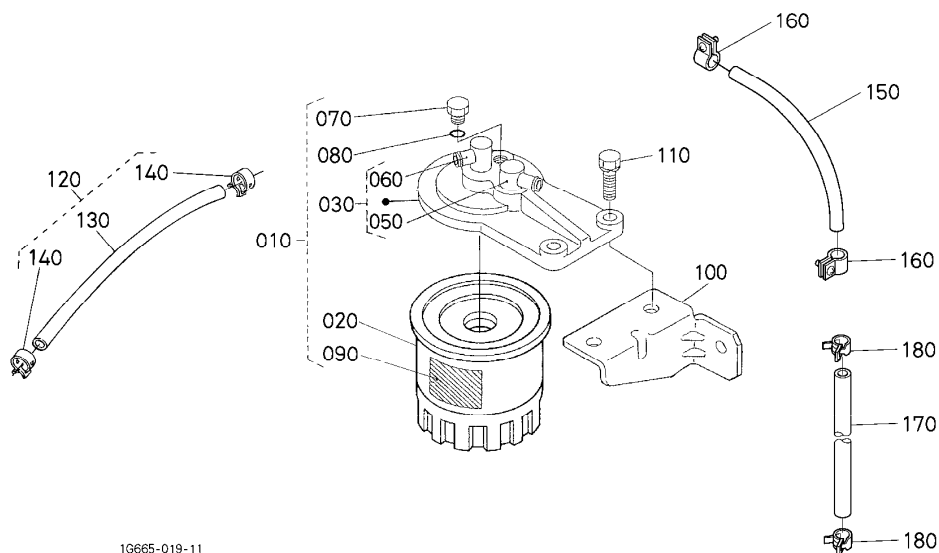

1G665-019-11

A:V1505-EB-HAYTER-1

REF. No. POS. No. BILD-Nr.	PART No. REFERENCE BESELL-Nr.	PART NAME	DESIGNATION	BEZEICHUNG	Q'TY/S. No. Q'TE/No. S. STUECK/S. Nr.		I. C.	REMARKS REMARQUES BEMERKUNGEN
					A	B		
010	15224-4301-0	ASSY FILTER, FUEL	ENS. FILTRE, COMBUST	GRP. KRAFTSTOFFFILTER	1	-		
020	15221-4317-0	ELEMENT, FILTER	ELEMENT DE FILTRE	FILTREINSATZ	1	-		
030	15224-4320-0	ASSY COVER, FILTER	ENS. DE COUVERCLE	GRP. DECKEL	1	-		
040	---	BLANK	BLANC	LEERE SPALTE	-	-		
050	15108-4361-0	JOINT, PIPE	RACCORD DE TUYAU	SCHALTUNG	1	-		
060	15108-4378-0	JOINT, PIPE	RACCORD DE TUYAU	SCHALTUNG	1	-		
070	19222-4328-0	PLUG, FILTER BREATHER	BOUCHON D'EVENT DE F	STOUPSEL, FILTER ENTL	1	-		
080	15108-4329-0	O RING	JOINT TORIQUE	O RING	1	-		
090	15224-8776-0	MARK, FORM	MARQUE DE TYPE	MARKIERUNG	1	-		
100	16286-4343-0	HOLDER, FUEL FILTER	SUPPORT DE FILTER	HALTERUNG	1	-		
110	01123-50822	BOLT	VIS	BOLZEN	2	-		
120	16286-4202-0	ASSY PIPE, FUEL	ENS. TUYAU CARBURANT	GRP. KRAFTSTOFFROHR	1	-		
130	09661-80270	TUBE, FUEL	TUYAU	KRAFTSTOFFROHR	1	-		
140	14911-4275-0	CLIP, PIPE	ATTACHE	ROHRKLEMME	2	-		
150	15905-4211-0	PIPE, FUEL	TUYAU DE COMBUSTIBLE	KRAFTSTOFFROHR	1	-		
160	14301-4275-0	CLIP, PIPE	ATTACHE	ROHRKLEMME	4	-		
170	19268-4252-0	PIPE, FUEL OVER FLOW	TUYAU DE TROP-PLEIN	KRAFSTOFFU-LAUFROHR	1	-		
180	10244-4232-0	CLIP, PIPE	ATTACHE	ROHRKLEMME	6	-		

↔ Interchangeable; ≠ not interchangeable; ← new for old; → old for new

0301 FUEL PUMP (MECHANICAL)

POMPE D' ALIMENTATION (MECHANIQUE)

KRAFTSTOFFPUMPE (MECHANISCH)

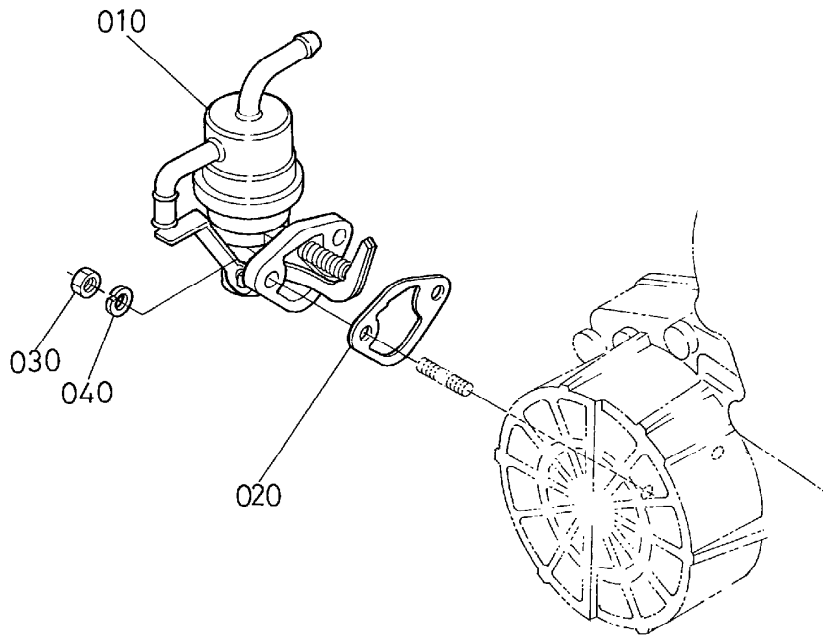

16615-012-10

A:V1505-EB-HAYTER-1

REF. No. POS. No. BILD-Nr.	PART No. REFERENCE BESELL-Nr.	PART NAME	DESIGNATION	BEZEICHNUNG	Q' TY/S. No. Q' TE/No. S. STUECK/S. Nr.		I. C.	REMARKS REMARQUES BEMERKUNGEN
					A	B		
010	16285-5203-2	ASSY PUMP, FUEL	ENS. POMPE D' ALIMEN.	GRP. KRAFTSTOFFPUMPE	1	-		
020	16264-5214-0	GASKET, FUEL PUMP	JOINT DE POMP. CARB.	DICHUNG, PUMPE	1	-		
030	02056-50060	NUT	ECROU	MUTTER	2	-		
040	04512-60060	WASHER, SPRING	RONDELLE GROWER	FEDERRING	2	-		

↔ Interchangeable; ≠ not interchangeable; ← new for old; → old for new

0402

ALTERNATOR AND PULLEY ALTERNATEUR WECHSELSTROMMASCHINE

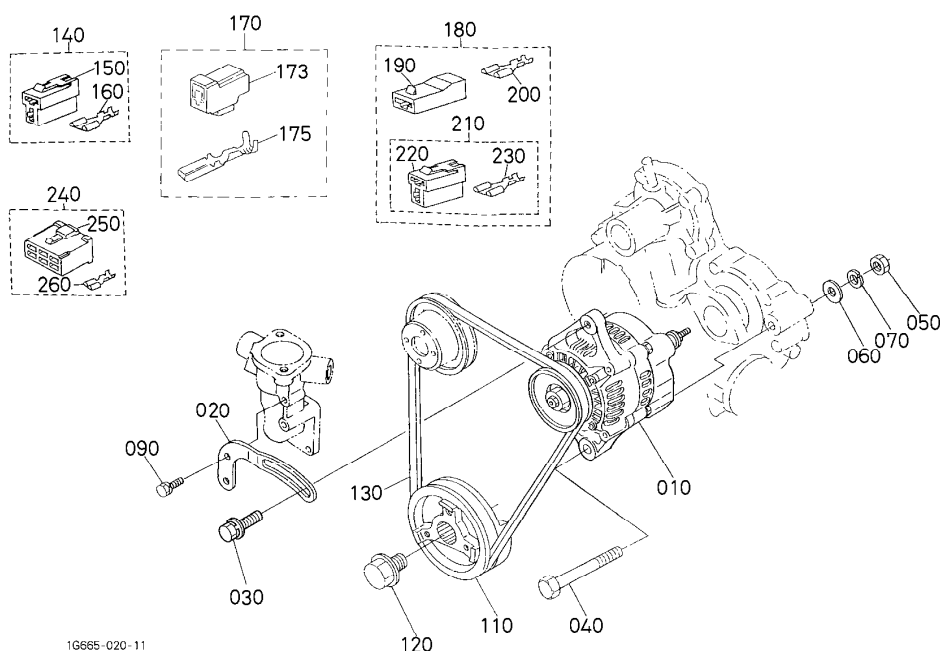

1G665-020-11

OLD PARTS

1G685-812-10

A:V1505-EB-HAYTER-1

REF. No. POS. No. BILD-Nr.	PART No. REFERENCE BESELL-Nr.	PART NAME	DESIGNATION	BEZEICHNUNG	Q'TY/S. No. Q'TE/No. S. STUECK/S. Nr.		I. C.	REMARKS REMARQUES BEMERKUNGEN
					A	B		
010	16241-6401-2	ASSY ALTERNATOR	ALTERNATEUR COMPLET	GRP. WECHSELSTROMDYN.	1	-		
020	16241-6442-0	STAY, DYNAMO	TENDEUR	DYNAMOSTANGE	1	-		
030	01127-50830	BOLT	VIS	BOLZEN	1	-		
040	01173-51085	BOLT	VIS	BOLZEN	1	-		
050	02176-50100	NUT	ECROU	MUTTER	1	-		
060	04011-50100	WASHER, PLAIN	RONDELLE FREIN	SCHEIBE	1	-		
070	04512-60100	WASHER, SPRING	RONDELLE GROWER	FEDERRING	1	-		
080	----	BLANK	BLANC	LEERE SPALTE	-	-		
090	01023-50616	BOLT	VIS	BOLZEN	1	-		
100	----	BLANK	BLANC	LEERE SPALTE	-	-		
110	16249-7428-0	PULLEY, FAN DRIVE	POULIE ENTRAIN. VENT.	RIEMENSCHLEIBE	1	-		
120	16241-9102-0	BOLT, FAN DRIVE	VIS	BOLZEN	1	-		
130	16282-9701-0	V BELT	COURROIE	RIEMEN	1	-		
140	19838-6583-0	ASSY COUPLER	ENS. COUPLEUR	GRP. KUPPLER	1	-		
150	19872-6588-0	CONNECTOR	CONNECTEUR	ANSCHLUBE	1	-		
160	19237-6591-0	TERMINAL	DEBORNE	ANSCHLUBKLEMME	2	-		
170	16259-6583-0	ASSY COUPLER, LOCK	ENS. COUPLEUR VERROU	GRP. KUPPLERKONTERMU.	1	-		
170	1C010-6583-0	ASSY COUPLER	ENS. COUPLEUR	GRP. KUPPLER	<=5V2555	-		
173	1C010-6588-0	CONNECTOR	CONNECTEUR	ANSCHLUBE	>=5W0009	-		
175	1C010-6591-0	TERMINAL	DEBORNE	ANSCHLUBKLEMME	>=5W0009	-		
180	16239-6583-0	ASSY COUPLER, RELAY	ENS. COUPLEUR RELAIS	GRP. KUPPLERRELAIS	1	-		
190	16239-6588-0	CONNECTOR	CONNECTEUR	ANSCHLUBE	2	-		
200	16239-6577-0	TERMINAL	DEBORNE	ANSCHLUBKLEMME	2	-		
210	19838-6583-0	ASSY COUPLER	ENS. COUPLEUR	GRP. KUPPLER	1	-		
220	19872-6588-0	CONNECTOR	CONNECTEUR	ANSCHLUBE	1	-		
230	19237-6591-0	TERMINAL	DEBORNE	ANSCHLUBKLEMME	2	-		
240	16662-6583-0	ASSY COUPLER, CONNec.	ENS. COUPLEUR CONNec.	GRP. KUPPLERANSCHLUBE	1	-		
250	19872-6584-0	CONNECTOR	CONNECTEUR	ANSCHLUBE	1	-		
260	19237-6591-0	TERMINAL	DEBORNE	ANSCHLUBKLEMME	5	-		

↔ Interchangeable; ≠ not interchangeable; ← new for old; → old for new

0403

ALTERNATOR (COMPONENT PARTS)
 ALTERNATEUR (PARTIES COMPOSANTES)
 WECHSELSTROMMASCHINE (EINZEL-TEIL)

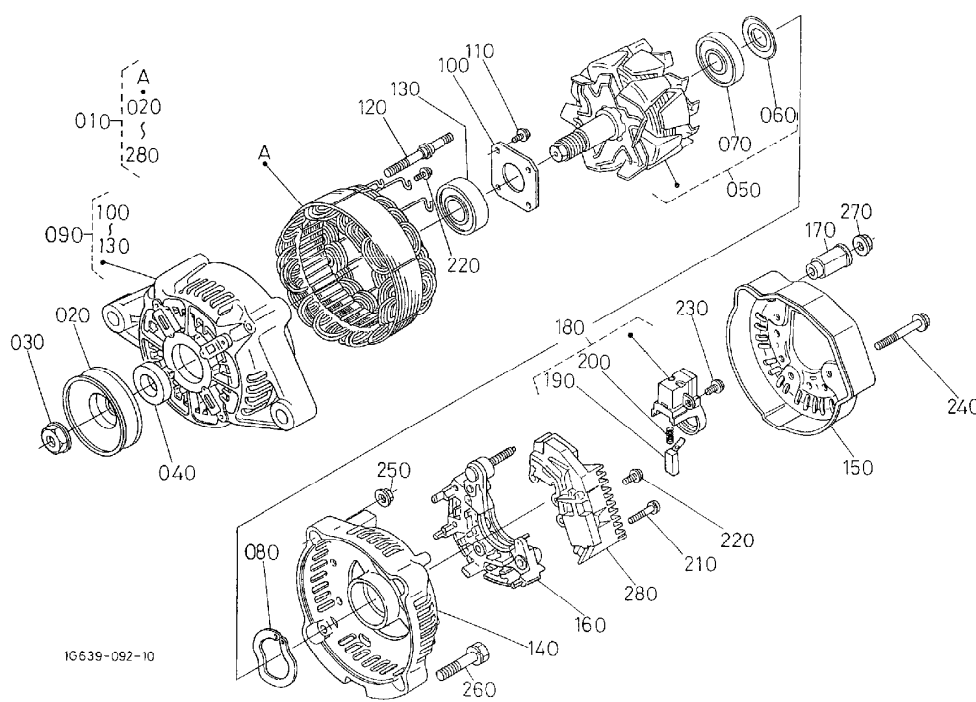

IG639-092-10

A:V1505-EB-HAYTER-1

REF. No. POS. No. BILD-Nr.	PART No. REFERENCE BESELL-Nr.	PART NAME	DESIGNATION	BEZEICHNUNG	Q' TY/S. No. Q' TE/No. S. STUECK/S. Nr.		I. C.	REMARKS REMARQUES BEMERKUNGEN
					A	B		
010	16241-6401-2	ASSY ALTERNATOR	ALTERNATEUR COMPLET	GRP. WECHSELSTROMDYN.	1	-		
020	15881-6411-0	PULLEY, DYNAMO	POULIE D' ALTERNATEUR	RIEMENSCHLEIBE, DYNAMO	1	-		
030	15881-9201-0	NUT	ECROU	MUTTER	1	-		
040	15881-6415-0	COLLAR	COLLIER	HUELSE	1	-		
050	66436-6404-0	ROTOR	ROTOR	ROTOR	1	-		
060	15881-6480-0	COVER, BEARING	COUVERCLE	DECKEL	1	-		
070	16652-6477-0	BEARING, BALL	ROULEMENT A BILLES	KUGELLAGER	1	-		
080	15881-6481-0	WASHER, THRUST	RONDELLE DE BUTEE	DRUCKSCHEIBE	1	-		
090	66436-6402-0	FRAME, DRIVE END	BATI	ANTRIEBSRAHMEN	1	-		
100	15881-6471-0	PLATE, RETAINER	PLAQUE RETENUE	HALTEPLATTE	1	-		
110	15881-9301-0	SCREW, ROUND HEAD	VIS A TETE RONDE	RUNDKOPFSCHRAUBE	4	-		
120	15881-6426-0	BOLT, THROUGH	VIS. PASSANT	DURCHGEHENDERBOLZEN	2	-		
130	16652-6478-0	BEARING, BALL	ROULEMENT A BILLES	KUGELLAGER	1	-		
140	16231-6406-0	FRAME, END	BATI	RAHMEN	1	-		
150	16231-6423-0	COVER, END	PALIER ARRIERE	DECKEL	1	-		
160	16231-6485-0	ASSY RECTIFIER	REDRESSEUR	MONT. GLEICHRICHTER	1	-		
170	16241-6490-0	BUSH, INSULATION	BAGUE ISOLANTE	BUCHSE	1	-		
180	16652-6431-0	HOLDER, BRUSH	PORTE-BALAI	BUERSTEN HALTER	1	-		
190	15881-6409-0	BRUSH	PATTE D' ATTACHE	BUERSTE	2	-		
200	15881-6433-0	SPRING, BRUSH	RESSORT DE BALAI	SCHLEIFBUERSTENFEDER	2	-		
210	15881-9302-0	SCREW, ROUND HEAD	VIS A TETE RONDE	RUNDKOPFSCHRAUBE	2	-		
220	15881-9303-0	SCREW, ROUND HEAD	VIS A TETE RONDE	RUNDKOPFSCHRAUBE	6	-		
230	15881-9304-0	SCREW, ROUND HEAD	VIS A TETE RONDE	RUNDKOPFSCHRAUBE	1	-		
240	15881-9104-0	BOLT	VIS	BOLZEN	3	-		
250	15881-9202-0	NUT	ECROU	MUTTER	2	-		
260	15881-9105-0	BOLT	VIS	BOLZEN	2	-		
270	14182-9203-0	NUT	ECROU	MUTTER	1	-		
280	1K531-6460-0	ASSY REGULATOR	REGULATEUR	REGULATOR	1	-		NOT SALE
280	1K531-6460-2	ASSY REGULATOR	REGULATEUR	REGULATOR	≤=4T1477 1 >=4U0001	-		←

↔ Interchangeable; ≠ not interchangeable; ← new for old; → old for new

0404

STARTER
DEMARREUR
ANLASSER

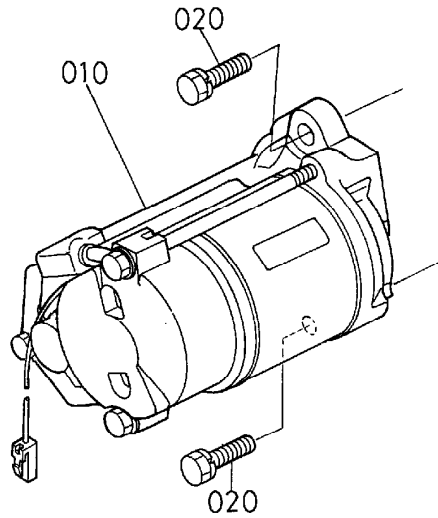

16614-022-10

A:V1505-EB-HAYTER-1

REF. No. POS. No. BILD-Nr.	PART No. REFERENCE BESELL-Nr.	PART NAME	DESIGNATION	BEZEICHNUNG	Q' TY/S. No. Q' TE/No. S. STUECK/S. Nr.		I. C.	REMARKS REMARQUES BEMERKUNGEN
					A	B		
010	16611-6301-0	ASSY STARTER	ENS. DEMARREUR	GRP. ANLASSER	1	-		
020	01123-50830	BOLT	VIS	BOLZEN	2	-		

0405

STARTER (COMPONENT PARTS)
 DEMARREUR (PARTIES COMPOSANTES)
 ANLASSER (EINZEL-TEIL)

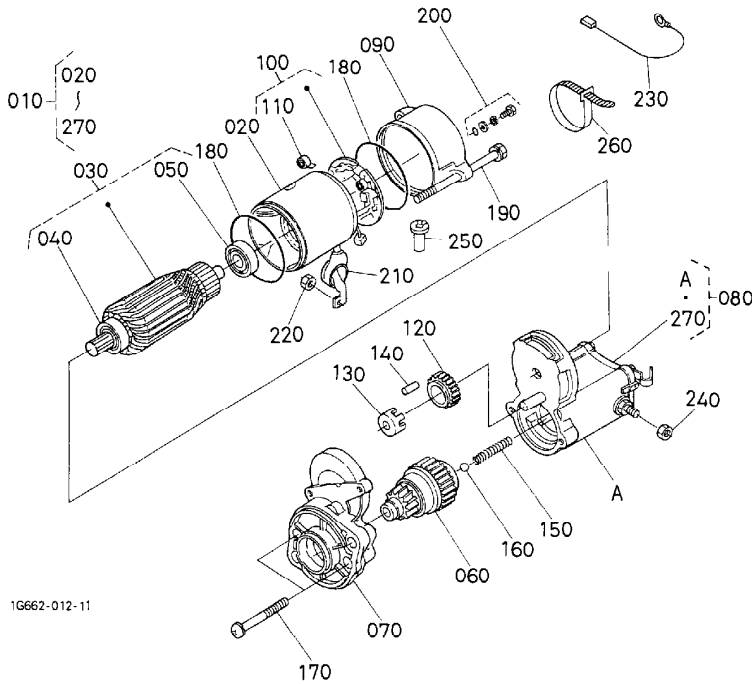

1G662-012-11

A: V1505-EB-HAYTER-1

REF. No. POS. No. BILD-Nr.	PART No. REFERENCE BESELL-Nr.	PART NAME	DESIGNATION	BEZEICHNUNG	Q' TY/S. No. Q' TE/No. S. STUECK/S. Nr.		I. C.	REMARKS REMARQUES BEMERKUNGEN
					A	B		
010	16611-6301-0	ASSY STARTER	ENS. DEMARREUR	GRP. ANLASSER	1	-		
020	16661-6308-0	ASSY YOKE	ENS. CHAPE	GRP. GABELGELENK	1	-		
030	11197-6307-0	ASSY ARMATURE	ENS. ARMATURE	GRP. ARMATUR	1	-		
040	11460-6350-0	BEARING	ROULEMENT	LAGER	1	-		
050	11460-6353-0	BEARING	ROULEMENT	LAGER	1	-		
060	16611-6304-0	CLUTCH, OVER RUNNING	EMBRAYAGE A INERTIE	AUFFLAUFKUPPLUNG	1	-		
070	16611-6303-0	FRAME, DRIVE END	BATI	ANTRIEBSRAHMEN	1	-		
080	16611-6302-0	ASSY SWITCH, MAGNETIC	ENS. INTERRUPTEUR	GRP. MAGNETSCHALTER	1	-		
090	17341-6320-0	FRAME, END	BATI	RAHMEN	1	-		
100	11197-6338-0	ASSY HOLDER, BRUSH	ENS. SUPPORT	GRP. BÜRSTENHALTER	1	-		
110	15401-6339-0	SPRING, BRUSH	RESSORT DE BALAI	SCHLEIFBÜRSTENFEDER	4	-		
120	11460-6327-0	GEAR	ENGRENAGE	GETRIEBE	1	-		
130	11460-6311-0	RETAINER	SUPPORT	HALTESCHEIBE	1	-		
140	19212-6310-0	ROLLER	ROULEAU	ROLLE	6	-		
150	11460-6312-0	SPRING	RESSORT	FEDER	1	-		
160	19212-9713-0	BALL	BILLE	KUGEL	1	-		
170	11460-9331-0	BOLT	VIS	BOLZEN	2	-		
180	15511-9666-0	O RING	JOINT TORIQUE	O RING	2	-		
190	11197-6332-0	BOLT	VIS	BOLZEN	2	-		
200	15511-6376-0	ASSY BOLT	ENS. VIS	GRP. BOLZEN	2	-		
210	16611-6345-0	COVER	COUVERCLE	DECKEL	1	-		
220	16611-9202-0	NUT, HEXAGON	ECROU HEXAGONAL	MUTTER	1	-		
230	16611-6366-0	CORD, STOP SOLENOID	PRISE DE SOLENOIDE	CABLESTOPSOLENOID	1	-		
240	16285-9201-0	NUT, HEXAGON	ECROU HEXAGONAL	MUTTER	1	-		
250	16285-6357-0	PIPE, DRAIN	TUYAU DE DRAINAGE	DRANLEITUNG	1	-		
260	16612-6310-0	BAND, COVER	BANDE, COUVERCLE	FLACHRIEMEN	1	-		
270	16285-9805-0	ASSY COVER	ENS. COUVERCLE	GRP. DECKEL	1	-		

↔ Interchangeable; ≠ not interchangeable; ← new for old; → old for new

0406

OIL SWITCH/THERMOMETER AND PLUG
 CONTACT A HUILE/THERMOMETRE ET OBTURATEUR
 OELSCHALTER/THERMOMETER UND VERSCHILUSSSTOPFEN

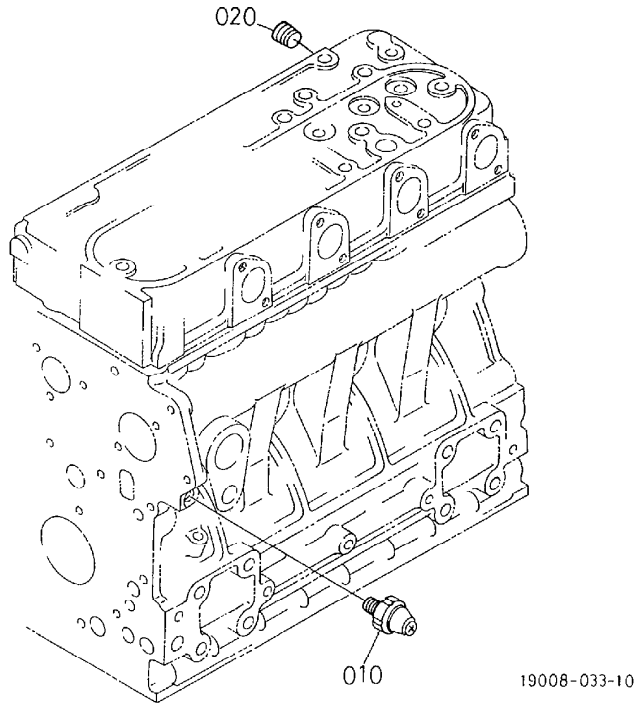

A:V1505-EB-HAYTER-1

REF. No. POS. No. BILD-Nr.	PART No. REFERENCE BESELL-Nr.	PART NAME	DESIGNATION	BEZEICHNUNG	QTY/S. No. QTE/No. S. STUECK/S. Nr.		I. C.	REMARKS REMARQUES BEMERKUNGEN
					A	B		
010	15841-3901-0	SWITCH, OIL	MANO-CONTACT D' HUILE	OELDRUCKSCHALTER	1	-		
020	15841-9602-0	PLUG	BOUCHON	STOPFEN	1	-		

↔ Interchangeable; ≠ not interchangeable; ← new for old; → old for new

0500

WATER FLANGE AND THERMOSTAT BRIDE A EAU ET THERMOSTAT WASSERFLANSCH UND THERMOSTAT

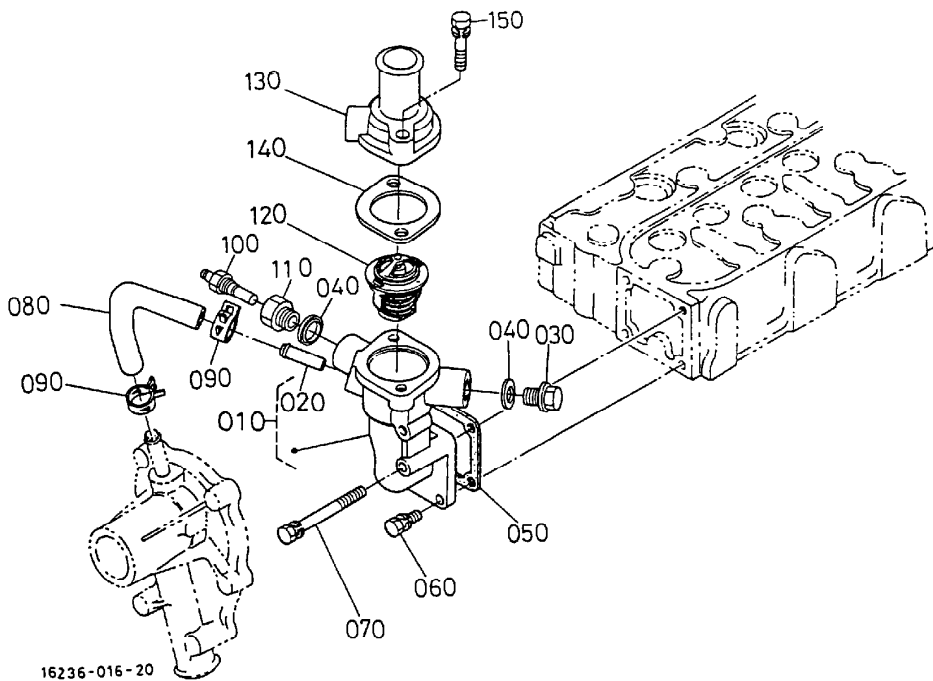

16236-016-20

A:V1505-EB-HAYTER-1

REF. No. POS. No. BILD-Nr.	PART No. REFERENCE BESELL-Nr.	PART NAME	DESIGNATION	BEZEICHNUNG	Q'TY/S. No. Q'TE/No. S. STUECK/S. Nr.		I. C.	REMARKS REMARQUES BEMERKUNGEN
					A	B		
010	19008-7270-0	COMP. FLANGE, WATER	BRIDE A EAU COMP.	KOMP. FLANSCH	1	-		
020	16241-7337-0	PIPE, WATER RETURN	TUYAU RETOUR D'EAU	WASSERROHR	1	-		
030	06311-55030	PLUG	BOUCHON	STOPFEN	1	-		
040	16261-9671-0	GASKET	JOINT	DICHTUNGSPLATTE	2	-		
050	16264-7292-0	GASKET, WATER FLANGE	JOINT DE BRIDE	DICHTUNG	1	-		
060	01023-50616	BOLT	VIS	BOLZEN	3	-		
070	01023-50655	BOLT	VIS	BOLZEN	1	-		
080	16241-7335-0	PIPE, WATER RETURN	TUYAU RETOUR D'EAU	WASSERROHR	1	-		
090	16241-7336-0	BAND, PIPE	COLLIER DE TUYAU	ROHRBAND	2	-		
100	16222-8304-0	ASSY THERMOSWITCH	ENS. THERMOINTERRUPT.	GRP. THERMOZUENDSCHA.	1	-		
110	16222-7284-0	ADAPTER	ADAPTEUR	ZWISCHENSTUECK	1	-		
120	19434-7301-4	ASSY THERMOSTAT	THERMOSTAT COMP.	GRP. THERMOSTAT	1	-		
130	16219-7326-0	COVER, THERMOSTAT	COUV. DE THERMOSTAT	DECKEL, THERMOSTAT	1	-		
140	16221-7327-0	GASKET, THERMOSTAT	JOINT	DICHTUNG	1	-		
150	01123-50835	BOLT	VIS	BOLZEN	2	-		

↔ interchangeable; ≠ not interchangeable; ← new for old; → old for new

0501

**WATER PUMP
POMPE A EAU
WASSERPUMPE**

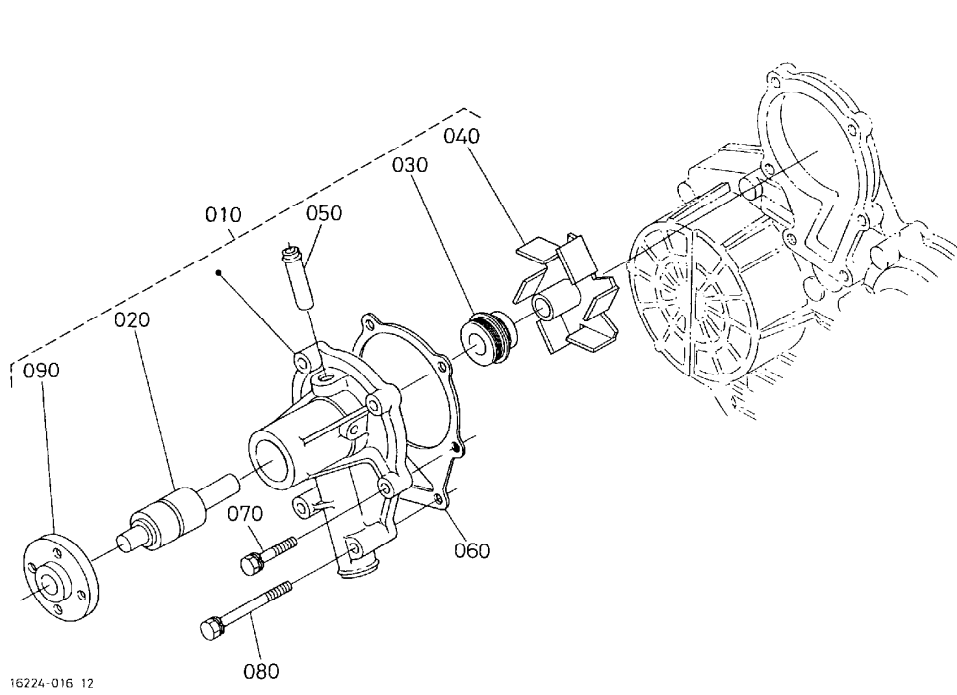

16224-016 12

A:V1505-EB-HAYTER-1

REF. No. POS. No. BILD-Nr.	PART No. REFERENCE BESELL-Nr.	PART NAME	DESIGNATION	BEZEICHNUNG	Q' TY/S. No. Q' TE/No. S. STUECK/S. Nr.		I. C.	REMARKS REMARQUES BEMERKUNGEN
					A	B		
010	16251-7303-4	ASSY PUMP, WATER	ENS. POMPE A EAU	GRUPPE WASSERPUMPE	1	-		
020	16259-7355-2	BEARING	ROULEMENT	LAGER	1	-		
030	16642-7305-0	ASSY SEAL, MECHANICAL	ENS. JOINT MECANIQUE	GRP. MECH. DICTUNG	1	-		
040	16259-7351-2	IMPELLER, WATER PUMP	TURBINE DE POMPE	FLUEGELRAD	1	-		
050	16241-7334-0	PIPE, WATER RETURN	TUYAU RETOUR D'EAU	WASSERROHR	1	-		
060	16239-7343-0	GASKET, WATER PUMP	JOINT DE POMPE A EAU	DICTUNG, WASSERPUMPE	1	-		
070	01023-50630	BOLT	VIS	BOLZEN	4	-		
080	01023-50685	BOLT	VIS	BOLZEN	2	-		
090	16259-7352-0	FLANGE, WATER PUMP	BRIDE DE POMPE A EAU	FLANSCH, PUMPE	1	-		

↔ Interchangeable; ≠ not interchangeable; ← new for old; → old for new

0503

**WATER PIPE
TUYAU D'EAU
WASSERROHR**

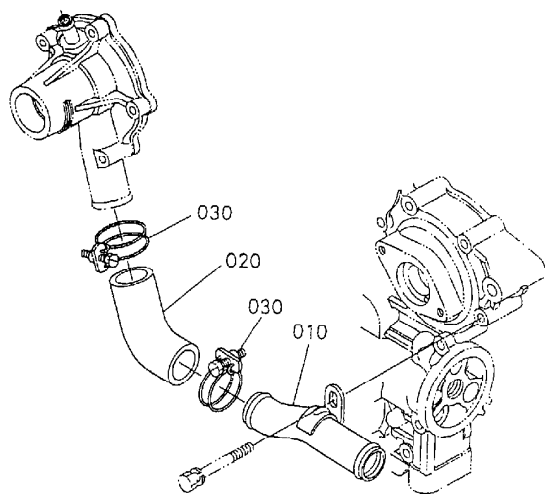

IG345-010-20

A:V1505-EB-HAYER-1

REF. No. POS. No. BILD-Nr.	PART No. REFERENCE BESELL-Nr.	PART NAME	DESIGNATION	BEZEICHNUNG	QTY/S. No. Q'TE/No. S. STUECK/S. Nr.		I. C.	REMARKS REMARQUES BEMERKUNGEN
					A	B		
010	17203-7286-0	PIPE, WATER	TUYAU D'EAU	WASSERROHR	1	-		
020	1G680-7287-0	PIPE, WATER	TUYAU D'EAU	WASSERROHR	1	-		
030	36200-8272-0	CLAMP	ATTACHE	KLAMMER	2	-		

↔ Interchangeable; ≠ not interchangeable; ← new for old; → old for new

0504 FAN
VENTILATEUR
VENTILATOR

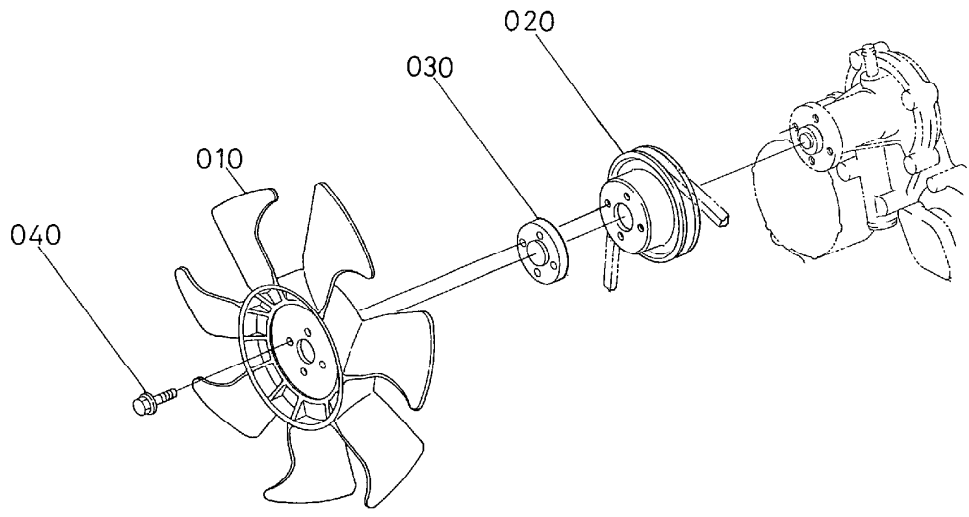

1G299-034-10

A:V1505-EB-HAYTER-1

REF. No. POS. No. BILD-Nr.	PART No. REFERENCE BESELL-Nr.	PART NAME	DESIGNATION	BEZEICHNUNG	Q'TY/S. No. Q' TE/No. S. STUECK/S. Nr.		I. C.	REMARKS REMARQUES BEMERKUNGEN
					A	B		
010	16285-7411-0	FAN	VENTILATEUR	VENTILATOR	1	-		
020	16241-7425-0	PULLEY, FAN	POULIE VENTILATEUR	VENTILATORSCHEIBE	1	-		
030	15876-7415-2	COLLAR, FAN	COLLIER	VENTILATORHUELSE	1	-		
040	01754-50620	BOLT, FLANGE	VIS DE BUTEE	FLANSCHEN-BOLZEN	4	-		

↔ Interchangeable; ≠ not interchangeable; ← new for old; → old for new

0600

VALVE AND ROCKER ARM SOUPAPES ET CULBUTEURS VENTIL UND KIPPENARM

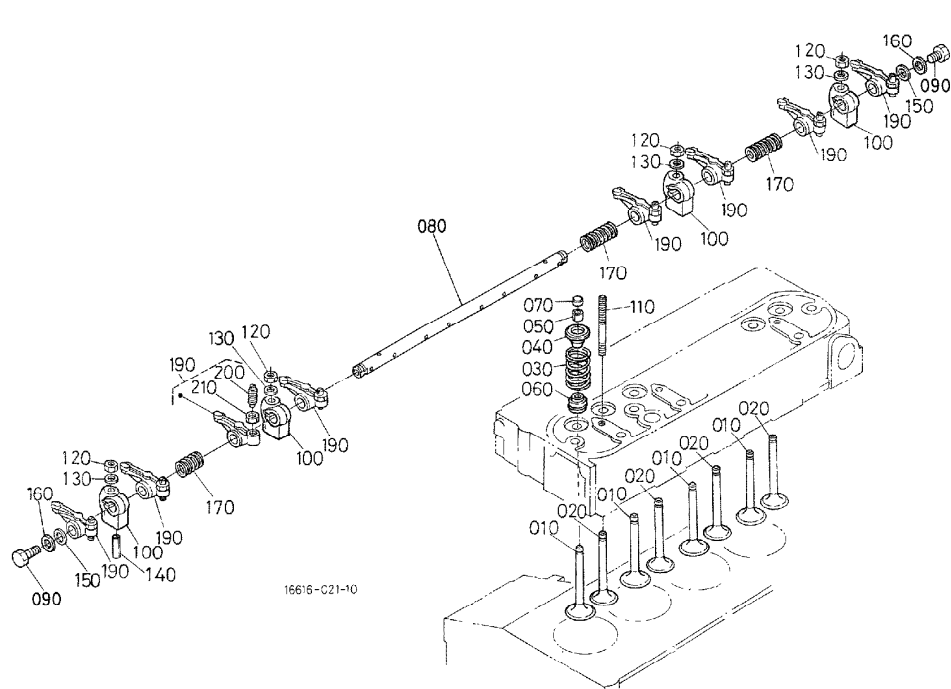

16616-C21-10

A:V1505-EB-HAYTER-1

REF. No. POS. No. BILD-Nr.	PART No. REFERENCE BESELL-Nr.	PART NAME	DESIGNATION	BEZEICHNUNG	QTY/S. No. Q' TE/No. S. STUECK/S. Nr.		I. C.	REMARKS REMARQUES BEMERKUNGEN
					A	B		
010	16241-1311-0	VALVE, INLET	SOUPAPE D'ADMISSION	EINLASSVENTIL	4	-		
020	16241-1312-0	VALVE, EXHAUST	SOUPAPE D'ECHAPMENT	AUSLASSVENTIL	4	-		
030	16271-1324-0	SPRING, VALVE	RESSORT DE SOUPAPE	VENTIL-FEDER	8	-		
040	16261-1333-0	RETAINER, SPRING	ARRETOIR DE RESSORT	HALTBUEGEL, FEDER	8	-		
050	15261-1336-0	COLLET, VALVE SPRING	DEMI CLAVETTE	KLEMMSCHEIBE	8	-		SET
060	10010-1315-0	SEAL, VALVE STEM	JOINT DE SOUPAPE	VENTILDICHTUNG	8	-		
070	16241-1328-0	CAP, VALVE	CHAPEAU DE SOUPAPE	VENTILKAPPE	8	-		
080	16241-1426-4	SHAFT, ROCKER ARM	ARBRE DE CULBUTEUR	KIPPHEBELWELLE	1	-		
090	01023-50610	BOLT	VIS	BOLZEN	2	-		
100	16241-1435-0	BRACKET, ROCKER ARM	SUPPORT DE CULBUTEUR	KIPPHEBELHALTER	4	-		
110	16241-1441-0	STUD	GOUJON	STEBOLZEN	4	-		
120	15261-9201-0	NUT	ECROU	MUTTER	4	-		
130	15261-9401-0	WASHER, PLAIN	RONDELLE FREIN	SCHEIBE	4	-		
140	05411-00428	PIN, SPRING	GOUJON-RESSORT	STIFT, FEDR	1	-		
150	16241-1443-0	WASHER, R-ARM. SHAFT	RONDELLE	SCHEIBE	2	-		
160	15841-9402-2	WASHER, PLAIN	RONDELLE FREIN	SCHEIBE	2	-		
170	16241-1431-0	SPRING, ROCKER ARM	RESSORT DE CULBUTEUR	FEDER, KIPPHEBEL	3	-		
180		BLANK	BLANC	LEERE SPALTE	-	-		
190	16241-1403-2	ASSY ROCKER ARM	ENS. CULBUTEURS	GRP. KIPPHEBEL	8	-		
200	16241-1423-0	SCREW, ADJUSTING	VIS DE REGLAGE	STELLSCHRAUBE	8	-		
210	16241-1424-0	NUT	ECROU	MUTTER	8	-		

↔ Interchangeable; ≠ not interchangeable; ← new for old; → old for new

0601

INLET MANIFOLD COLLECTEUR D'ADMISSION ANSAUGENLEITUNG

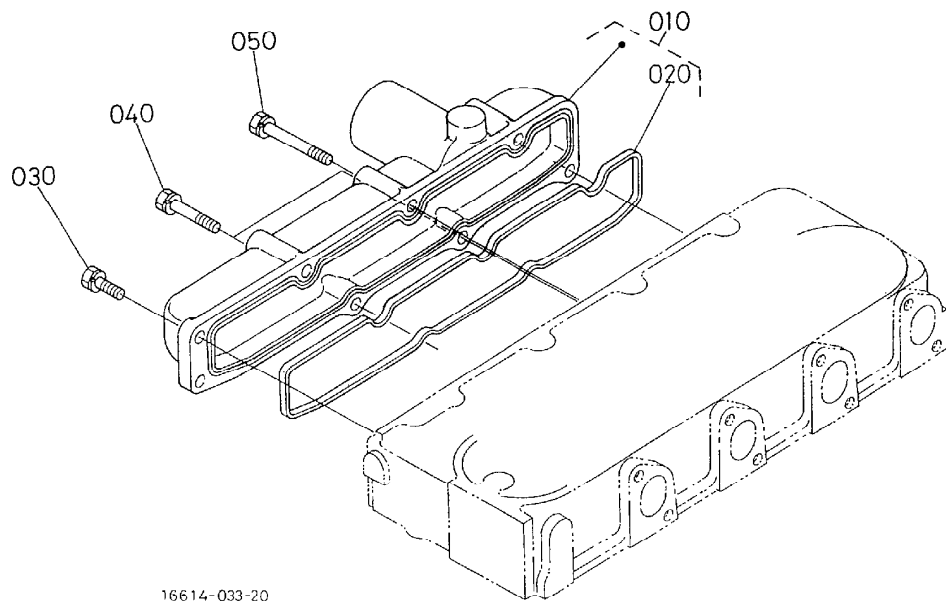

16614-033-20

A:V1505-EB-HAYTER-1

REF. No. POS. No. BILD-Nr.	PART No. REFERENCE BESELL-Nr.	PART NAME	DESIGNATION	BEZEICHNUNG	Q'TY/S. No. Q'TE/No. S. STUECK/S. Nr.		I. C.	REMARKS REMARQUES BEMERKUNGEN
					A	B		
010	16271-1177-0	ASSY MANIFOLD, INLET	ENS. COLLECTEUR D' AD.	GRP. ANSAUG-ROHRKRUE.	1	-		
020	16241-1182-0	GASKET, IN-MANIFOLD	JOINT DE COLL. ADM.	DICHTUNG ANSAUGROHR	1	-		
030	01023-50618	BOLT	VIS	BOLZEN	3	-		
040	01023-50630	BOLT	VIS	BOLZEN	2	-		
050	01023-60650	BOLT	VIS	BOLZEN	3	-		

↔ Interchangeable; ≠ not interchangeable; ← new for old; → old for new

0602

EXHAUST MANIFOLD COLLECTEUR D' ECHAPPEMENT AUSPUFFRUEMMER

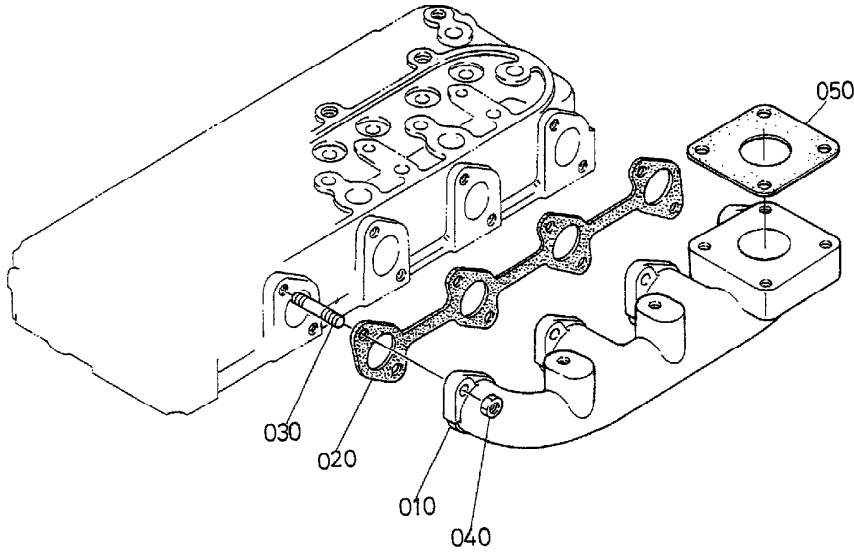

16614-007-20

A:V1505-EB-HAYTER-1

REF. No. POS. No. BILD-Nr.	PART No. REFERENCE BESELL-Nr.	PART NAME	DESIGNATION	BEZEICHNUNG	Q' TY/S. No. Q' TE/No. S. STUECK/S. Nr.		I. C.	REMARKS REMARQUES BEMERKUNGEN
					A	B		
010	16283-1231-0	MANIFOLD, EXHAUST	COLLECTEUR D' ECHAPP.	AUSPUFFROHR	1	-		
020	16299-1236-0	GASKET, EX-MANIFOLD	JOINT DE COLL. ECHAP.	DICHTUNG, AUSPUFFPOHR	1	-		
030	16241-9149-0	STUD	GOUJON	STEBBOLZEN	8	-		
040	16271-9201-0	NUT	ECROU	MUTTER	8	-		
050	15263-1237-0	GASKET, MUFFLER NA	JOINT	DICHTUNG, AUSPUFFT. NA	2	-		

**0604 INLET PIPE
TUYAU D'ADMISSION
ANSAUGENROHR**

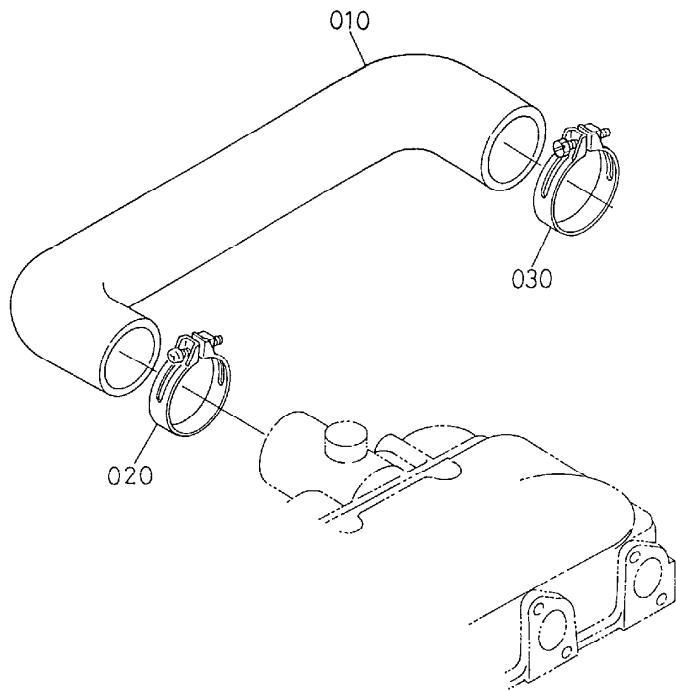

17592-002-11

A:V1505-EB-HAYTER-1

REF. No. POS. No. BILD-Nr.	PART No. REFERENCE BESELL-Nr.	PART NAME	DESIGNATION	BEZEICHNUNG	Q' TY/S. No. Q' TE/No. S. STUECK/S. Nr.		I. C.	REMARKS REMARQUES BEMERKUNGEN
					A	B		
010	16616-1162-0	PIPE, INLET	TUYAU D'ADMISSION	SAUGROHR	1	-		
020	15401-1172-0	BAND, PIPE	COLLIER DE TUYAU	ROHRBAND	2	-		
030	15221-1172-0	BAND, PIPE	COLLIER DE TUYAU	ROHRBAND	2	-		

↔ Interchangeable; ≠ not interchangeable; ← new for old; → old for new

0605 MUFFLER
SILENCIEUX
AUSPUFFTOPF

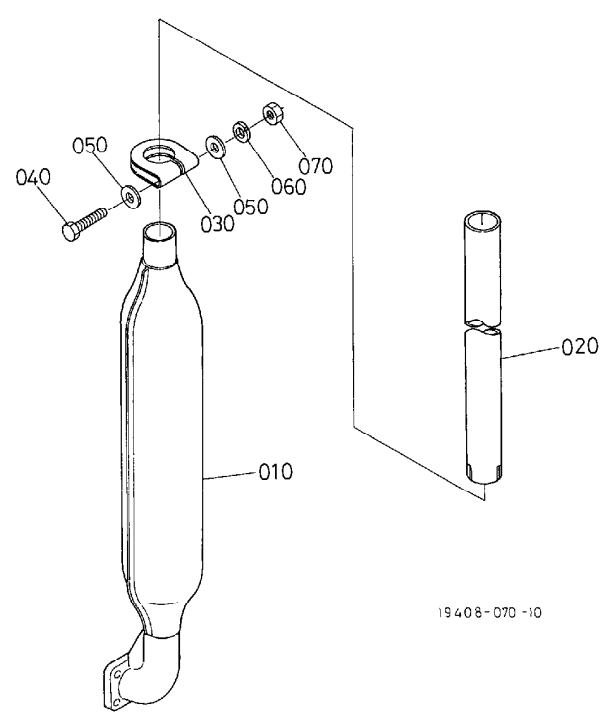

A:V1505-EB-HAYTER-1

REF. No. POS. No. BILD-Nr.	PART No. REFERENCE BESELL-Nr.	PART NAME	DESIGNATION	BEZEICHNUNG	QTY/S. No. QTE/No.S. STUECK/S.Nr.		I. C.	REMARKS REMARQUES BEMERKUNGEN
					A	B		
010	15442-1211-0	MUFFLER	SILENCIEUX	AUSPUFFTOPF	1	-		
020	15221-1241-3	PIPE, MUFFLER	TUYAU DE SILENCIEUX	AUSPUFFTOPFRÖHR	1	-		
030	15221-1243-3	CLAMP, MUFFLER PIPE	COLLIER DE TUYAU	EINSPANNBAND	1	-		
040	01053-50860	BOLT	VIS	BOLZEN	1	-		
050	04013-60080	WASHER, PLAIN	RONDELLE FREIN	SCHEIBE	2	-		
060	04512-60080	WASHER, SPRING	RONDELLE GROWER	FEDERRING	1	-		
070	02114-50080	NUT	ECROU	MUTTER	1	-		

↔ Interchangeable; ≠ not interchangeable; ← new for old; → old for new
36

0700

HYDRAULIC PUMP
POMPE HYDRAULIQUE
HYDRAULIKPUMPE

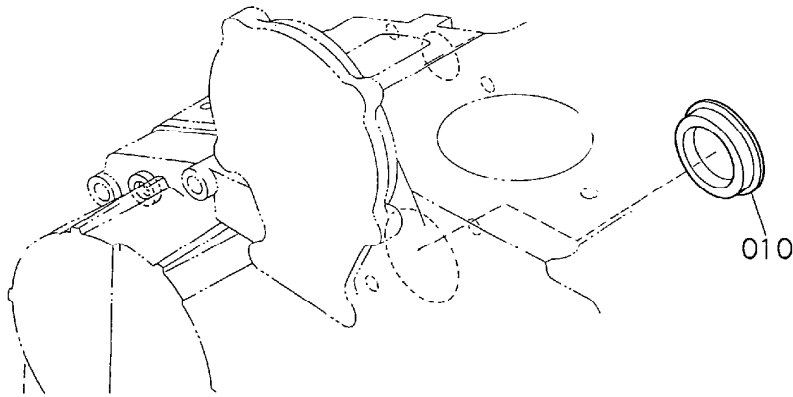

1K571-016-10

A:V1505-EB-HAYTER-1

REF. No. POS. No. BILD-Nr.	PART No. REFERENCE BESELL-Nr.	PART NAME	DESIGNATION	BEZEICHNUNG	QTY/S.No. QTE/No.S. STUECK/S.Nr.		I.C.	REMARKS REMARQUES BEMERKUNGEN
					A	B		
010	16264-8315-2	COVER, HYDRAULIC PUMP	COUVERGLE, POMPE HYD.	DECKELHYDRAULIKPUMPE	1	-		
010	16264-8315-3	COVER, HYDRAULIC PUMP	COUVERGLE, POMPE HYD.	DECKELHYDRAULIKPUMPE	1	-	←	

↔ Interchangeable; ≠ not interchangeable; ← new for old; → old for new

0800

GLOW LAMP AND TIMER
 INDICATEUR DE PRECHAUFFAGE ET TEMPORISATEUR
 GLUEHLAMPE UND ZEITMESSER

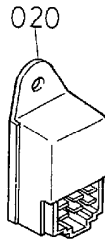
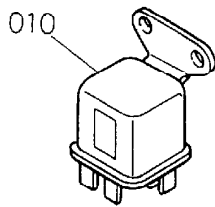

16226-037-10

A:V1505-EB-HAYTER-1

REF. No. POS. No. BILD-Nr.	PART No. REFERENCE BESELL-Nr.	PART NAME	DESIGNATION	BEZEICHNUNG	QTY/S. No. Q' TE/No. S. STUECK/S. Nr.		I. C.	REMARKS REMARQUES BEMERKUNGEN
					A	B		
010	16259-6025-0	ASSY RELAY	ENS. RELAIS	GRP. RELAIS	1	-		
020	15694-6599-0	TIMER, GLOW LAMP	TEMPORISATEUR	LAMPETREMBLEUR	1	-		

↔ Interchangeable; ≠ not interchangeable; ← new for old; → old for new

0809

LABEL AND OPERATOR'S MANUAL
 ETIQUETTE ET MANUEL DE L'UTILISATEUR
 ETIKETTE UND HANDHABUNG-GEBRAUCHSANWEISUNG

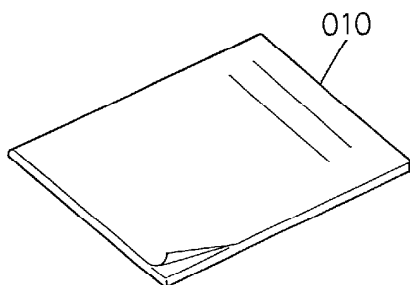

1K532-016-10

A:V1505-EB-HAYTER-1

REF. No. POS. No. BILD-Nr.	PART No. REFERENCE BESELL-Nr.	PART NAME	DESIGNATION	BEZEICHNUNG	Q'TY/S. No. Q'TE/No. S. STUECK/S. Nr.		I. C.	REMARKS REMARQUES BEMERKUNGEN
					A	B		
010	16622-8916-4	OPERATOR'S MANUAL	MANUEL DE L'UTILISA.	DETDIENUNGSANLEITUNG	1	-		

↔ Interchangeable; ≠ not interchangeable; ← new for old; → old for new

**NUMERICAL INDEX
INDEX NUMERIQUE
NUMERISCHEN INDEX**

PART No. REFERENCE BESELL-Nr.	PAGE PAGE SEITE	REF. No. POS. No. BILD-Nr.	PART No. REFERENCE BESELL-Nr.	PAGE PAGE SEITE	REF. No. POS. No. BILD-Nr.	PART No. REFERENCE BESELL-Nr.	PAGE PAGE SEITE	REF. No. POS. No. BILD-Nr.	PART No. REFERENCE BESELL-Nr.	PAGE PAGE SEITE	REF. No. POS. No. BILD-Nr.
E9151-3314-0	5	110	05012-00410	4	100	15521-2396-0	11	210	16032-5390-0	19	005
01023-50610	32	090	05012-00508	1	100	15521-9361-0	1	180	16032-9203-0	19	020
01023-50614	20	120	05012-00814	1	110		9	050	16032-9404-0	19	080
01023-50616	9	090	05411-00420	17	050	15521-9602-0	1	070	16032-9810-0	19	100
	9	180	05411-00428	32	140		4	025	16032-9850-0	19	110
	13	100	05712-00518	9	070	15601-9665-0	1	240	16032-9851-0	19	110
	17	140	06311-55030	28	030		14	050	16032-9852-0	19	110
	23	090	07715-00201	4	070		14	100	16032-9853-0	19	110
	28	060	07715-00401	10	110		17	160	16032-9854-0	19	110
01023-50618	13	080	07715-03205	20	066		18	030	16032-9855-0	19	110
01023-50618	33	030	09661-80270	21	130	15694-6599-0	38	020	16032-9856-0	19	110
01023-50620	8	080	10244-4232-0	21	180	15841-3901-0	27	010	16032-9857-0	19	110
01023-50625	8	070	11197-6307-0	26	030	15841-4250-0	18	040	16032-9858-0	19	110
01023-50630	29	070	11197-6332-0	26	190	15841-4252-0	18	045	16032-9859-0	19	110
	33	040	11197-6338-0	26	100	15841-5135-0	16	130	16040-1617-0	13	010
01023-50645	4	120	11460-6311-0	26	130	15841-5136-0	18	020	16040-5209-2	16	050
01023-50655	4	140	11460-6312-0	26	150	15841-5362-2	18	070	16040-5211-2	16	050
	28	070	11460-6327-0	26	120		19	120	16040-5212-2	16	060
01023-50665	4	150	11460-6350-0	26	040	15841-5385-0	18	130	16060-0304-2	3	040
01023-50685	29	080	11460-6353-0	26	050	15841-5386-0	18	140	16060-2111-0	10	010
01023-60650	4	130	11460-9331-0	26	170	15841-7302-0	1	220	16060-2111-3	10	010
	33	050	14182-9203-0	24	270	15841-9150-0	16	080	16060-2111-4	10	010
01053-50618	17	150	14301-4275-0	21	160	15841-9202-0	14	030	16060-2191-0	10	010
01053-50860	36	040	14911-4275-0	16	030	15841-9232-0	16	090	16060-2191-3	10	010
01123-50822	21	110		21	140	15841-9402-2	32	160	16060-2191-4	10	010
01123-50830	25	020	14971-4275-0	18	050	15841-9602-0	27	020	16060-5101-0	16	040
01123-50835	28	150	15021-3366-0	1	210	15841-9665-0	16	120	16060-5423-0	20	065
01123-60814	3	030	15108-4329-0	21	080	15841-9666-0	16	140	16219-7326-0	28	130
	7	040	15108-4361-0	21	050	15852-9233-0	14	040	16221-5442-0	14	060
01123-60816	2	080	15108-4378-0	21	060		14	090	16221-5628-0	1	160
01127-50830	23	030	15221-0349-0	1	030	15876-7415-2	31	030	16221-7327-0	28	140
01173-51085	23	040	15221-1172-0	35	030	15881-6409-0	24	190	16221-9112-0	2	060
01311-10614	15	030	15221-1241-3	36	020	15881-6411-0	24	020	16221-9452-0	1	120
01311-10620	16	070	15221-1243-3	36	030	15881-6415-0	24	040	16222-5751-0	17	110
01754-50610	1	230	15221-13361-0	1	200	15881-6426-0	24	120	16222-7284-0	28	110
01754-50620	31	040	15221-4317-0	21	020	15881-6433-0	24	200	16222-8304-0	28	100
02056-50060	4	180	15224-4301-0	21	010	15881-6471-0	24	100	16226-3211-0	2	070
	17	180	15224-4320-0	21	030	15881-6480-0	24	060	16226-3211-4	2	070
	22	030	15224-8776-0	21	090	15881-6481-0	24	080	16231-6406-0	24	140
02114-50080	36	070	15231-3396-0	1	130	15881-9104-0	24	240	16231-6423-0	24	150
02176-50100	23	050	15241-3229-0	4	040	15881-9105-0	24	260	16231-6485-0	24	160
02761-50040	18	180	15261-0337-0	3	090	15881-9201-0	24	030	16239-6577-0	23	200
03017-50620	4	090	15261-1336-0	32	050	15881-9202-0	24	250	16239-6583-0	23	180
03024-50510	5	080	15261-9119-0	12	050	15881-9301-0	24	110	16239-6588-0	23	190
03024-50520	18	150	15261-9201-0	32	120	15881-9302-0	24	210	16239-7343-0	29	060
04011-50100	23	060	15261-9401-0	32	130	15881-9303-0	24	220	16241-0175-0	3	010
04011-50180	4	030	15261-9601-0	1	040	15881-9304-0	24	230	16241-0177-0	3	020
04013-60080	36	050		3	060	15905-4211-0	21	150	16241-0345-0	3	100
04512-60060	4	190	15263-1237-0	34	050	15951-9666-0	5	100	16241-0409-2	8	010
	15	040	15321-9626-0	3	050	15952-9233-0	5	090	16241-0421-2	4	200
04512-60060	16	100	15401-1172-0	35	020	16030-5132-0	16	110	16241-0446-0	8	050
	17	190	15401-6339-0	26	110	16032-5300-0	18	065	16241-0454-0	8	020
	22	040	15442-1211-0	36	010		19	010		8	095
04512-60080	36	060	15451-9627-0	1	020	16032-5316-0	19	060		8	120
04512-60100	23	070	15451-9667-0	2	050	16032-5317-0	19	040		8	140
04814-00090	7	030	15471-5798-0	17	100	16032-5323-0	19	030	16241-0456-0	8	100
04814-00100	17	040	15511-6376-0	26	200	16032-5328-0	19	070	16241-0462-0	12	040
04814-00160	2	090	15511-9666-0	26	180	16032-5335-0	19	050	16241-0481-3	8	040
04814-10280	10	170	15521-2353-0	11	210	16032-5361-0	19	090	16241-0514-0	5	040
04814-50300	5	120	15521-2395-0	11	210	16032-5390-0	18	060	16241-0515-0	5	050

**NUMERICAL INDEX
INDEX NUMERIQUE
NUMERISCHEN INDEX**

PART No. REFERENCE BESELL-Nr.	PAGE PAGE SEITE	REF. No. POS. No. BILD-Nr.	PART No. REFERENCE BESELL-Nr.	PAGE PAGE SEITE	REF. No. POS. No. BILD-Nr.	PART No. REFERENCE BESELL-Nr.	PAGE PAGE SEITE	REF. No. POS. No. BILD-Nr.	PART No. REFERENCE BESELL-Nr.	PAGE PAGE SEITE	REF. No. POS. No. BILD-Nr.
16241-0537-0	5	070	16241-5621-0	20	130	16264-8334-2	4	240	16299-5626-0	20	110
16241-0551-0	5	130	16241-5625-0	20	100	16265-9667-0	2	050	16299-5701-5	17	010
16241-0555-0	5	030	16241-5633-0	20	090	16271-1177-0	33	010	16299-6015-0	15	020
16241-0567-0	5	060	16241-5634-0	20	140	16271-1324-0	32	030	16326-3375-0	2	020
16241-1182-0	33	020	16241-5716-0	17	030	16271-1601-0	9	030	16394-0331-0	3	110
16241-1311-0	32	010	16241-6401-2	23	010	16271-1691-0	9	030	16611-3641-3	7	010
16241-1312-0	32	020		24	010	16271-2401-0	9	100	16611-6301-0	25	010
16241-1328-0	32	070	16241-6442-0	23	020	16271-2402-0	9	120		26	010
16241-1403-2	32	190	16241-6490-0	24	170	16271-2498-0	9	110	16611-6302-0	26	080
16241-1423-0	32	200	16241-7334-0	29	050		9	130	16611-6303-0	26	070
16241-1424-0	32	210	16241-7335-0	28	080	16271-3209-2	6	010	16611-6304-0	26	060
16241-1426-4	32	080	16241-7336-0	28	090	16271-4250-2	18	010	16611-6345-0	26	210
16241-1431-0	32	170	16241-7337-0	28	020	16271-5371-2	18	090	16611-6366-0	26	230
16241-1435-0	32	100	16241-7425-0	31	020	16271-5372-2	18	100	16611-9202-0	26	220
16241-1441-0	32	110	16241-9102-0	23	120	16271-5373-2	18	110	16612-6310-0	26	260
16241-1443-0	32	150	16241-9104-0	4	160	16271-5374-2	18	120	16614-2501-2	12	010
16241-1450-0	5	010	16241-9149-0	34	030	16271-5501-3	13	110	16616-0150-0	2	010
16241-1452-0	5	020	16241-9202-0	17	070	16271-5506-0	13	160	16616-1162-0	35	010
16241-1511-0	9	020	16241-9233-0	13	060	16271-5531-3	13	120	16622-8916-4	39	010
16241-1627-0	9	080	16241-9402-0	17	060	16271-5532-0	13	140	16652-6431-0	24	180
16241-1632-0	13	090	16241-9523-0	13	070	16271-5535-0	1	190	16652-6477-0	24	070
16241-1651-0	9	060	16241-9569-0	16	010	16271-5541-0	13	220	16652-6478-0	24	130
16241-2131-0	10	030	16241-9601-0	1	060	16271-5602-3	17	080	16661-6308-0	26	020
16241-2133-0	10	040	16241-9602-0	4	020	16271-5621-4	20	050	16662-6583-0	23	240
16241-2198-2	10	060	16241-9626-2	1	150	16271-5648-0	20	010	16683-9602-0	1	050
16241-2201-2	10	050	16245-9153-0	4	170	16271-5715-0	17	020	16813-6382-0	12	020
16241-2214-2	10	070	16245-9154-0	4	230	16271-5772-0	17	090	16851-6551-2	18	160
16241-2231-0	10	080		17	170	16271-5774-0	17	120	17203-7286-0	30	010
16241-2297-0	10	080	16249-7428-0	23	110	16271-6556-0	18	170	17208-6001-0	15	010
16241-2298-0	10	080	16251-0402-7	4	010	16271-9201-0	34	040	17341-6320-0	26	090
16241-2325-0	10	160	16251-3513-0	4	085	16271-9523-0	10	130	17391-9616-0	1	080
16241-2328-0	10	150	16251-7303-4	29	010	16271-9616-0	1	090	17558-0101-8	1	010
16241-2347-0	10	180	16252-0402-0	4	010	16272-5115-0	13	040	17558-0101-9	1	010
16241-2348-0	11	190	16252-0402-2	4	010	16282-0406-0	8	130	19008-7270-0	28	010
16241-2391-0	10	180	16259-6001-0	15	010	16282-2301-3	10	090	19077-5365-0	18	080
16241-2392-0	10	180	16259-6025-0	38	010	16282-3650-0	7	020		19	130
16241-2393-0	11	190	16259-6583-0	23	170	16282-9701-0	23	130	19202-2354-0	11	220
16241-2394-0	11	190	16259-7351-2	29	040	16283-1231-0	34	010	19202-2397-0	11	220
16241-2406-0	1	170	16259-7352-0	29	090	16285-0446-0	8	050	19202-2398-0	11	220
16241-2411-0	10	120	16259-7355-2	29	020	16285-5203-2	22	010	19212-6310-0	26	140
16241-2425-0	9	170	16261-0404-0	8	090	16285-5409-3	14	010	19212-9713-0	26	160
16241-2432-0	9	160	16261-0405-0	8	110	16285-5410-3	14	020	19222-4328-0	21	070
16241-2436-0	9	140	16261-1333-0	32	040	16285-5426-0	14	025	19237-6591-0	23	160
16241-2437-0	9	150	16261-1354-0	3	070	16285-5641-2	20	020		23	230
16241-2516-0	12	030	16261-1356-0	3	080	16285-6357-0	26	250		23	260
16241-3365-0	1	140	16261-1555-0	9	010	16285-7411-0	31	010	19268-4252-0	21	170
16241-3507-0	4	080	16261-2105-0	10	020	16285-9201-0	26	240	19434-7301-4	28	120
16241-3563-0	10	140	16261-2109-0	10	020	16285-9805-0	26	270	19484-5544-0	13	180
16241-3693-0	4	060	16261-9671-0	28	040	16286-3375-0	2	040		20	040
16241-3695-0	4	050	16261-9730-0	13	020	16286-4202-0	21	120	19838-6583-0	23	140
16241-4201-0	16	020	16261-9731-0	13	030	16286-4343-0	21	100	19838-6583-0	23	210
16241-5111-3	13	050	16261-9732-0	13	210	16292-2105-0	10	020	19872-6584-0	23	250
16241-5119-0	13	240	16264-0413-0	4	110	16292-2109-0	10	020	19872-6588-0	23	150
16241-5412-2	14	070	16264-0436-0	8	030	16292-2349-0	11	200		23	220
16241-5526-0	13	170	16264-0482-0	8	060	16292-2349-3	11	200	1C010-1315-0	32	060
16241-5527-0	13	150	16264-5214-0	22	020	16292-2386-0	11	200	1C010-6583-0	23	170
16241-5539-2	13	130	16264-5721-0	17	130	16292-2386-3	11	200	1C010-6588-0	23	173
16241-5545-0	13	190	16264-7292-0	28	050	16292-2387-0	11	200	1C010-6591-0	23	175
16241-5546-3	13	200	16264-8315-2	37	010	16292-2387-3	11	200	1G021-9665-0	14	110
16241-5555-4	13	230	16264-8315-3	37	010	16299-1236-0	34	020	1G031-5421-0	14	080

**NUMERICAL INDEX
INDEX NUMERIQUE
NUMERISCHEN INDEX**

PART No. REFERENCE BESELL-Nr.	PAGE PAGE SEITE	REF. No. POS. No. BILD-Nr.	PART No. REFERENCE BESELL-Nr.	PAGE PAGE SEITE	REF. No. POS. No. BILD-Nr.	PART No. REFERENCE BESELL-Nr.	PAGE PAGE SEITE	REF. No. POS. No. BILD-Nr.	PART No. REFERENCE BESELL-Nr.	PAGE PAGE SEITE	REF. No. POS. No. BILD-Nr.
1G032-5435-0...		14...075									
1G032-5613-0...		20...060									
1G032-5615-0...		20...070									
1G032-5647-0...		20...080									
1G069-5601-3...		20...030									
1G513-3655-0...		7...050									
1G642-7305-0...		29...030									
1G680-7287-0...		30...020									
1K531-6460-0...		24...280									
1K531-6460-2...		24...280									
36200-8272-0...		30...030									
66436-6402-0...		24...090									
66436-6404-0...		24...050									
6C090-5896-0...		2...030									